

OPTIONS AS SHOWN		
OPTION	PART #	DESCRIPTION
Tires	A000175/ A000304	Tire Assembly - 320/90 R46" 10 Bolt Small
Adj. Axle	N/A	N/A (Req. P000350)
Coupler Style	A000034	Hitch - Adj. (Req. A000017)

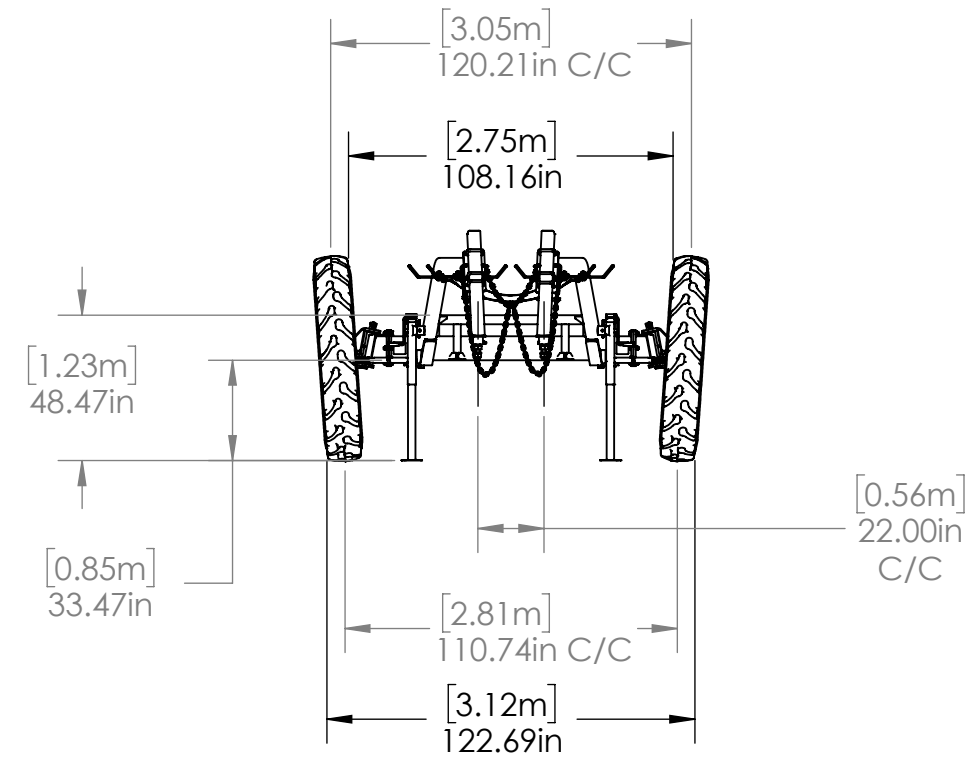

NOTE: ALL TIRE DIMENSIONS ARE APPROXIMATE

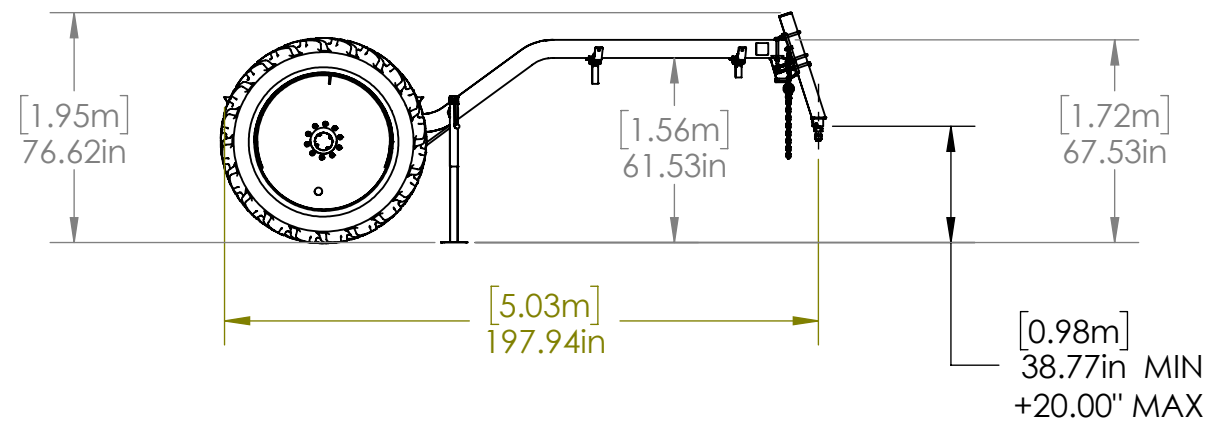
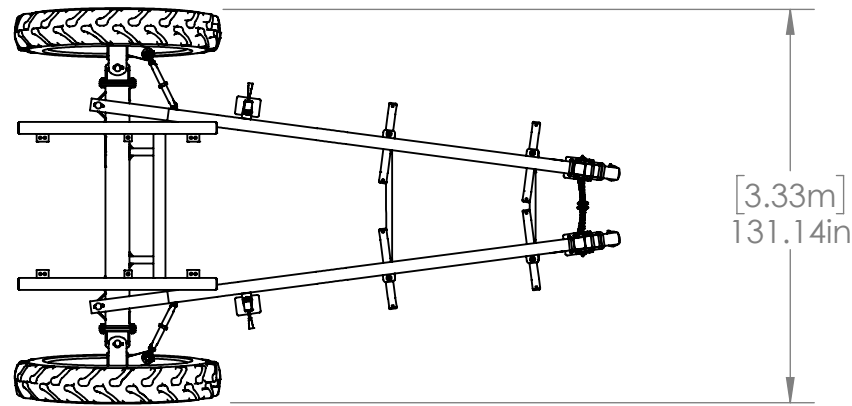

MONTAG MFG
3816 461st AVE,
Emmetsburg, IA 50536

P: 712-852-4572
F: 712-852-4574
www.montagmfg.com

DO NOT SCALE DRAWING
UNLESS OTHERWISE SPECIFIED:
DIMENSIONS ARE IN INCHES
1/X ± 1/32
.X ± .1
.XX ± .03
.XXX ± .010
ANGULAR ± 1°

CONFIDENTIAL: This drawing and design is proprietary and confidential to Montag Manufacturing, Inc.		
NAME	DATE	
DRAWN	SEC	10/20/21
APPROVED	CMF	08/24/23

TITLE:
**Auto-Steer Cart - 6Ton
Metric Adjustable Axle
(110")**

MATERIAL N/A
FINISH N/A

COMMENTS:

SIZE	PART. NO.	REV
B	C06M 2022	B-01
SCALE: 1:64	WEIGHT: 3436.8	SHEET 3 OF 7

NOTE: ALL TIRE DIMENSIONS ARE APPROXIMATE

OPTIONS AS SHOWN		
OPTION	PART #	DESCRIPTION
Tires	A000175/ A000304	Tire Assembly - 320/90 R46" 10 Bolt Small
Adj. Axle	N/A	N/A (Req. P-0350)
Coupler Style	A000020	Hitch - Knuckle Assembly (Req. W000237)

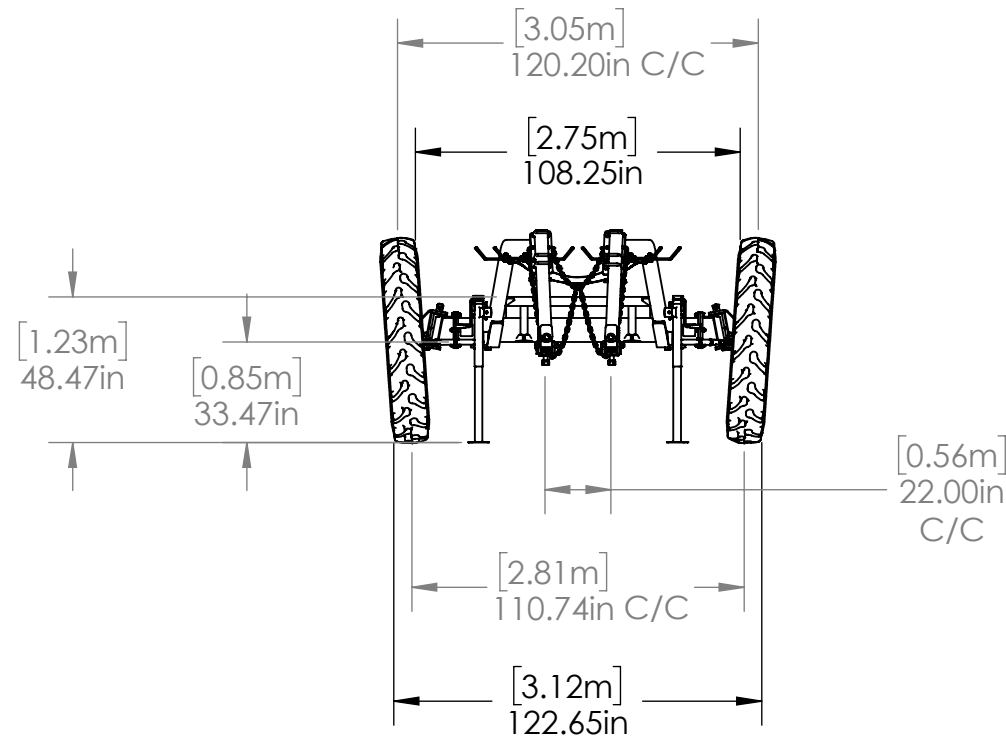
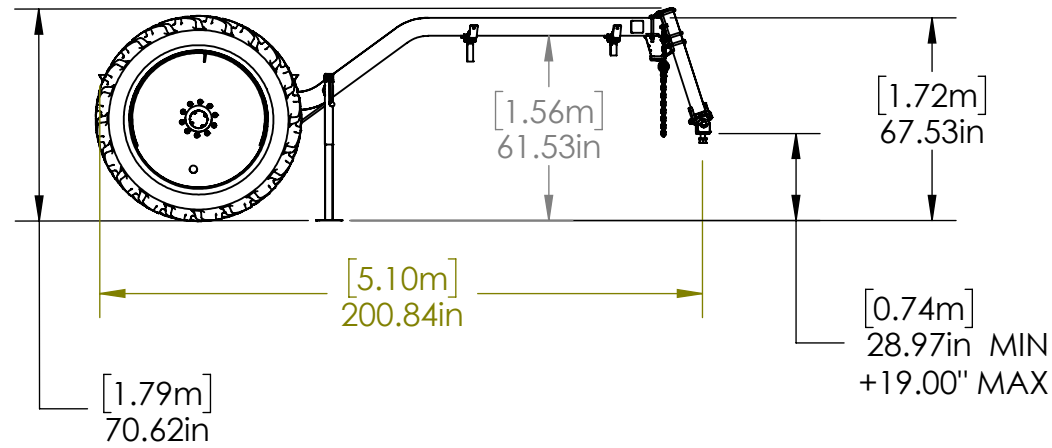
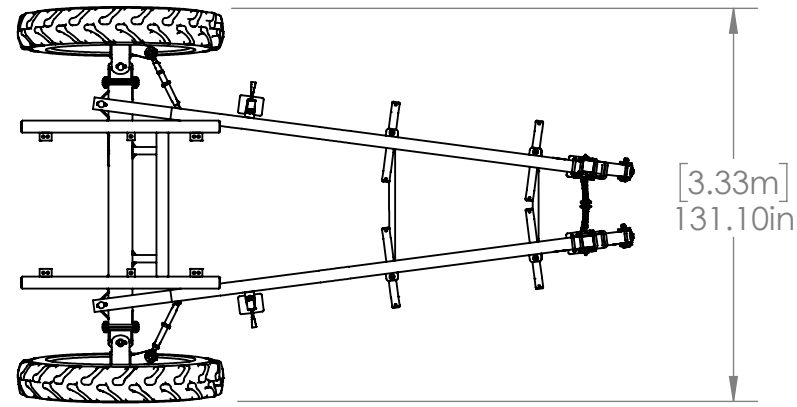

MONTAG MFG
3816 461st AVE,
Emmetsburg, IA 50536

P: 712-852-4572
F: 712-852-4574
www.montagmfg.com

DO NOT SCALE DRAWING
UNLESS OTHERWISE SPECIFIED:
DIMENSIONS ARE IN INCHES
1/X ± 1/32
.X ± .1
.XX ± .03
.XXX ± .010
ANGULAR ± 1°

CONFIDENTIAL: This drawing and design is proprietary and confidential to Montag Manufacturing, Inc.		
NAME	DATE	
DRAWN	SEC	10/20/21
APPROVED	CMF	08/24/23

TITLE:
**Auto-Steer Cart - 6Ton
Metric Adjustable Axle
(110")**

MATERIAL N/A
FINISH N/A

COMMENTS:

SIZE	PART. NO.	REV
B	C06M 2022	B-01
SCALE: 1:64	WEIGHT: 3436.8	SHEET 4 OF 7

C06MG
A000175/A000304
320/90 R46"

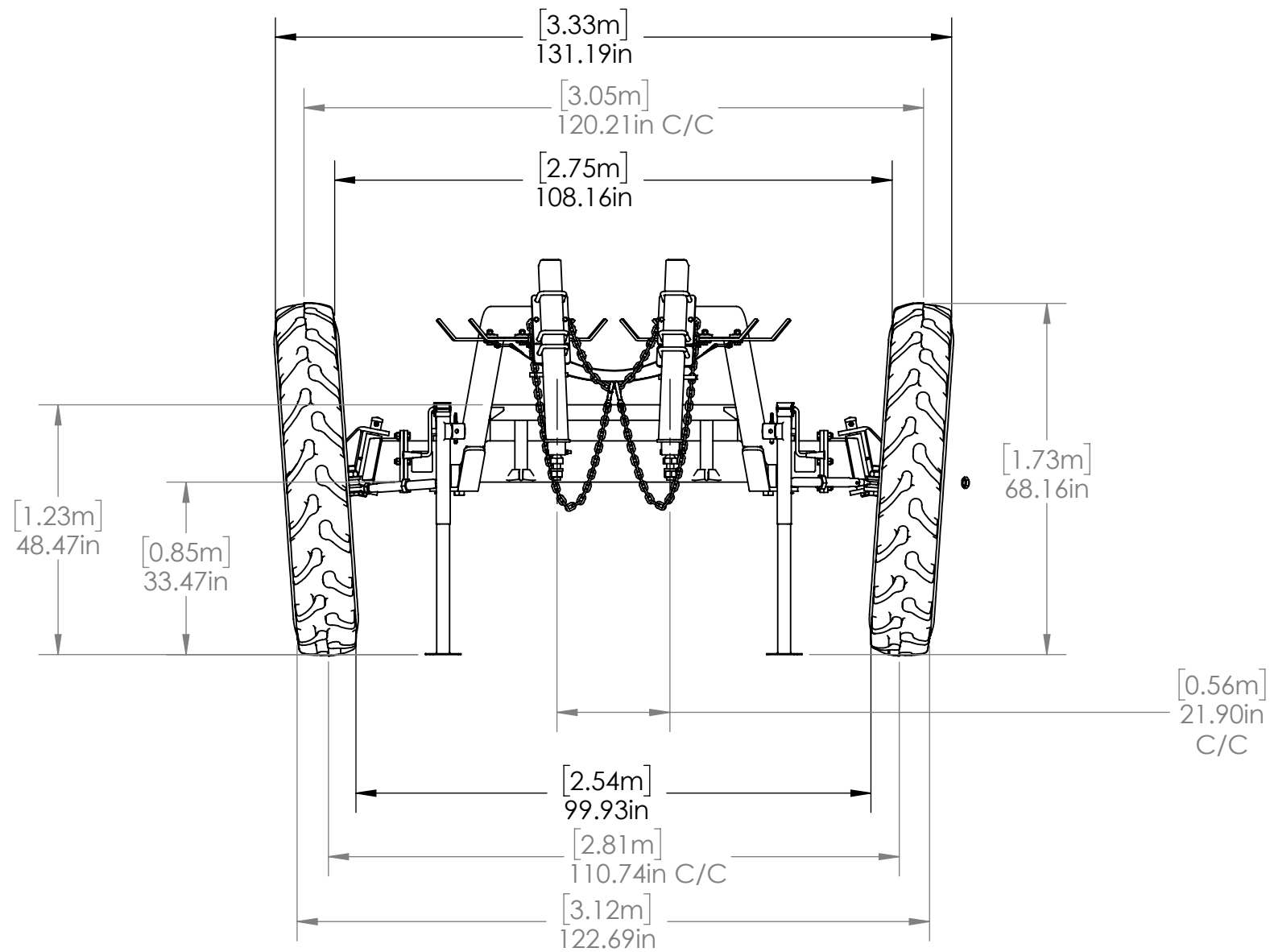

NOTE: ALL TIRE DIMENSIONS ARE APPROXIMATE



MONTAG MFG
 3816 461st AVE,
 Emmetsburg, IA 50536

P: 712-852-4572
 F: 712-852-4574
 www.montagmfg.com

DO NOT SCALE DRAWING
 UNLESS OTHERWISE SPECIFIED:
 DIMENSIONS ARE IN INCHES
 1/X ± 1/32
 .X ± .1
 .XX ± .03
 .XXX ± .010
 ANGULAR ± 1°

CONFIDENTIAL: This drawing and design is proprietary and confidential to Montag Manufacturing, Inc.		
NAME	DATE	
DRAWN	SEC	10/20/21
APPROVED	CMF	08/24/23

TITLE:
**Auto-Steer Cart - 6Ton
 Metric Adjustable Axle
 (110")**

MATERIAL N/A
 FINISH N/A

COMMENTS:

SIZE	PART. NO.	REV
B	C06M 2022	B-01
SCALE: 1:48 WEIGHT: 3436.8		SHEET 5 OF 7