

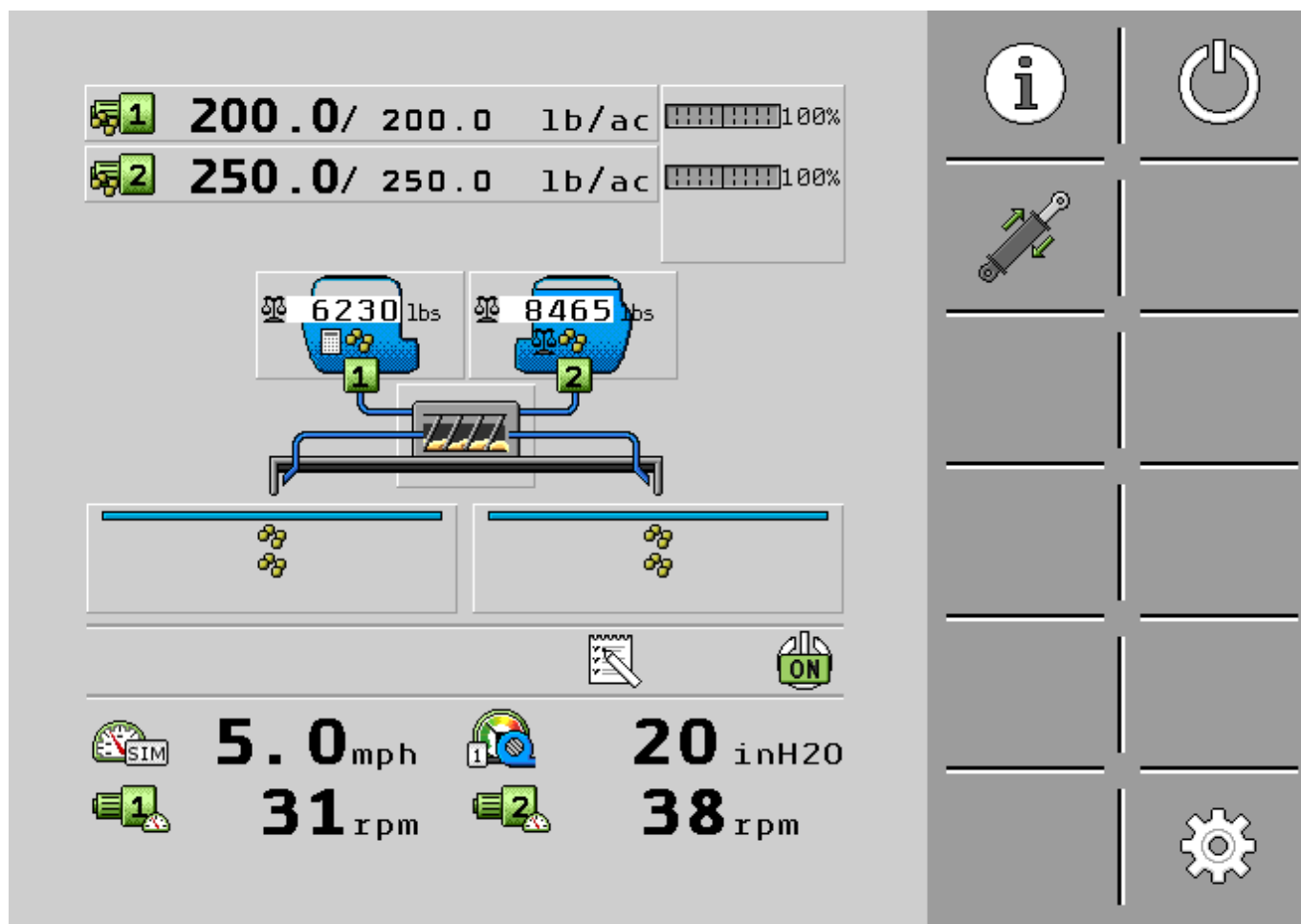

## MONTAG DRY RATE CONTROLLER OPERATOR MANUAL



Read and follow these operating instructions.

Keep these operating instructions for future reference.



SW Version 02.02.09.01

For updated manuals and additional supporting materials visit [www.montagmfg.com](http://www.montagmfg.com).

# Table of Contents

Introduction .....	2
Reference Links .....	2
Safety Information .....	2
Operator Manual Review .....	3
Basic Safety Instructions .....	3
Layout And Meaning of Warnings .....	4
About The ECU .....	5
ECU Functions .....	5
System Overview .....	5
About the Operating Instructions.....	8
Basic Control Principles .....	9
Road Mode Feature .....	10
Gen 2/ Fortifier Run Screen .....	11
Hopper Target / Actual Rates .....	12
Dry Rate Controller Display Area.....	13
Hopper Info .....	13
Status Line.....	14
Section Control.....	14
Visible Values .....	14
Run Screen .....	15
Function Buttons .....	15
Settings Screen.....	16
Hopper Settings .....	17
Metering Drive Settings.....	19
Metering Drive Calibration .....	20
Weigh System Settings .....	26
Fan Settings.....	27
Speed Signal Settings.....	27
Configuration Settings .....	30
Implement Configuration .....	31
Implement Geometry .....	33
Hopper Configuration.....	35
Shoot Configuration .....	36

Fan Configuration .....	37
Run Screen Configuration.....	39
Metering Unit Configuration.....	41
Product Configuration .....	43
Profile Database Configuration .....	45
Locked Area.....	45
Set-Up Guide.....	46
Operating the Implement in the Field .....	50
Start Applying .....	50
Filling Auger with Product .....	50
Stop Applying.....	50
Adjusting the Target Rate during Operation .....	51
Operating the Hydraulic System with the ECU .....	52
Montag Toolbox.....	52
Operating Section Control .....	53
Using Prescriptions .....	53
Viewing and Clearing Counters Page.....	53
Troubleshooting.....	56
Performing Diagnostics .....	56
Case Drain Alarm .....	60
Troubleshooting Guide .....	61
Updating Firmware on ECU controller.....	65
Technical Data.....	70
Gen 2 Harness Diagram .....	70
Gen 2 Cable Pin Diagrams.....	70
Gen 1 Harness Diagram .....	74
Gen 1 Cable Pin Diagrams.....	75
Fortifier Harness Diagram .....	76
Fortifier Cable Pin Diagrams.....	77
Montag Page Reference Guide.....	79
Calibration Chart for Machine Types .....	83

# Introduction

The Montag Dry Rate Controller (MDRC) is a dry rate controller programmed for all of Montag's dry fertilizer and cover crop machines. The MDRC connects to the ISOBUS plug on the back of the tractor to communicate through the monitor in the cab. The MDRC communicates with an ISOBUS scale, either Scale Tec Point or Digistar, to have an integrated system. This allows for in field calibration ability for precise fertilizer placement. It is the only controller on the market specific to Montag machines to control all features available. It will control up to 4 products at variable rate. It controls up to 4 sections for all 2 product machines through task control of the monitor. Many monitors are compatible with prescription, mapping and section control task controls. See [www.montagmfg.com](http://www.montagmfg.com) for the most up to date list of compatible monitors. In customer support page of the Montag's website are set-up instructions in printed form or video for future use.

This manual will guide the user through set-up and troubleshooting of the MDRC. Thank you for your confidence and patronage of one of Montag's offerings to the strip till consumer market.

To ensure safe, efficient, and trouble-free operation, all personnel who operate the equipment must read and understand the entire manual. It is the responsibility of the equipment owner to ensure that the operator is fully instructed and comprehends the contents of the manual.

The information contained in this manual was accurate at the time of publication. However, design or specification changes can be made at any time without prior notice, obligation, or liability. Refer to the [www.montagmfg.com](http://www.montagmfg.com) website for the most current information, updates, and documentation.

For detailed information regarding the installation, operation and safety instructions, and maintenance of optional equipment used with this product, please refer to the specific manuals provided for each component. Below is a list of reference links to the manuals for the available optional equipment.

## Reference Links

- GENERAL MONTAG SUPPORT INFORMATION
  - [SUPPORT - MONTAG MANUFACTURING, INC. \(MONTAGMFG.COM\)](http://www.montagmfg.com)

## Safety Information

The operator is responsible for their own safety as well as the safety of those around them when operating this equipment. This machine is designed and equipped with proper safety features, including machine guards and safety labels. Guards and safety labels must not be altered to protect the operator and bystanders from hazards that could cause serious injury.

Guards should only be removed for maintenance purposes and must be reinstalled prior to operation. Some of the illustrations in this manual may show the equipment with machine guards removed for clarity. Never operate this machine unless all machine guards are in place.

Do not attempt to operate this equipment under the influence of drugs or alcohol. Do not use the equipment if alertness or coordination is impaired.

This equipment is dangerous to children and persons unfamiliar with its operation. The operator should be a responsible adult familiar with farm machinery and trained in the operation of this equipment. Do not allow people

to operate or assemble this unit until they have read this manual and have developed a thorough understanding of the safety precautions and how the equipment works.

## **Operator Manual Review**

Operators should learn how to properly operate the machine and use its controls. Ensure the machine is kept in proper working condition and does not allow anyone to operate it without proper instruction.

During hitching, do not allow bystanders to stand between the tractor and implement, or between the implement and cart. Ensure all persons are clear of the working area.

Unauthorized modifications to the machine can impair its function and safety and may affect its lifespan. If you do not understand any part of this manual and need assistance, contact your dealer. Review the manual and safety labels before each season of use to ensure safe operation.

## **Basic Safety Instructions**

### **Operation**

Be sure to always comply with the following instructions during operation:

- Read the operating instructions for the Montag Implement controlled by using the product.
- Before leaving the vehicle cabin, ensure all automatic mechanisms are deactivated or manual mode is activated.
- Keep children away from the implement and from the ECU.

### **Servicing**

Keep the system in a functional condition. To do so, follow these instructions:

- Do not make any unauthorized modifications to the product. Unauthorized modifications or use may impair safety and reduce the service life or operability of the unit. Modifications are considered unauthorized if they are not described in the product documentation.
- Never remove any safety mechanisms or decal from the product.
- Before charging the tractor battery, always disconnect the ECU from the tractor.
- If any welding is performed on any part of the system, the ECU should be isolated from the frame and unplugged from power.
- The product does not include any user serviceable parts. Do not open the casing.

### **Intended Use**

The ISOBUS ECU is only intended for use in the agricultural sector, specifically a Montag implement. The manufacturer is not liable for any other installation or use of the ECU.

The manufacturer cannot be held liable for any personal injury or property damage resulting from such non-compliance. All risks arising from improper use lie with the user.

Intended use also includes compliance with the conditions for operation and repairs prescribed by the manufacturer.

All applicable accident prevention regulations and all other generally recognized safety, industrial, and medical standards, as well as all road traffic laws must be observed. Any unauthorized modifications made to the equipment will void the manufacturer's warranty.

### Layout And Meaning of Warnings

All safety instructions found in these Operating Instructions are composed in accordance with the following pattern:

	<b>! WARNING</b> This signal word identifies medium-risk hazards, which could potentially cause death or serious physical injury, if not avoided.
---	--

	<b>! CAUTION</b> This signal word identifies hazards that could potentially cause minor or moderate physical injury or damage to property, if not avoided.
---	---

<b>NOTICE</b>	
This signal word identifies hazards that could potentially cause damage to property, if not avoided.	

There are some actions that need to be performed in several steps. If there is a risk involved in carrying out any of these steps, a safety warning will appear in the instructions themselves.

Safety instructions always directly precede the step involving risk and can be identified by their bold font type and a signal word.

### Example

1. **NOTICE!** This is a notice. It warns that there is a risk involved in the next step.
2. Step involving risk.

### Safety Stickers for the Product



Do not clean with a high-pressure cleaner.

### Disposal



When it has reached the end of its service life, please dispose of this product as electronic scrap in accordance with all applicable waste management laws.

# About The ECU

## ECU Functions

The ISOBUS ECU is the control center of the Montag Dry Rate Controller (MDRC). Several sensors are connected to the ECU, which monitors important implement parts. The ECU controls the Montag implement based on these signals and on the operator's specifications. An ISOBUS terminal serves as an interface. All implement specific data is stored in the ECU and is therefore maintained even when changing the display.

Among other things, the ECU can perform the following tasks:

- Monitoring of the metering shaft
- Starting the calibration using the calibration button
- Monitoring the fan speed

## System Overview

The image below shows the Gen 2 cabling diagram for the MDRC System.

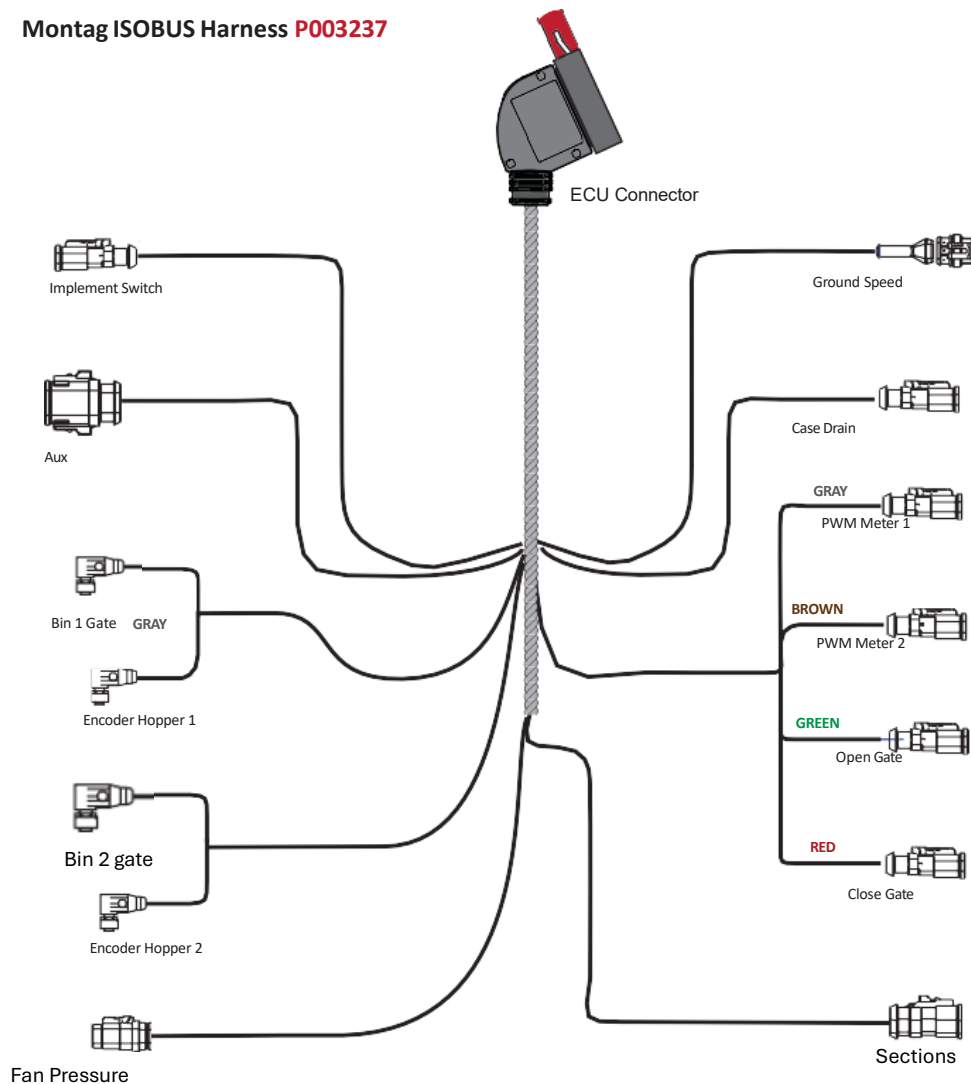

The following diagram shows how the Dry Rate Controller is structured on a **Gen 2**

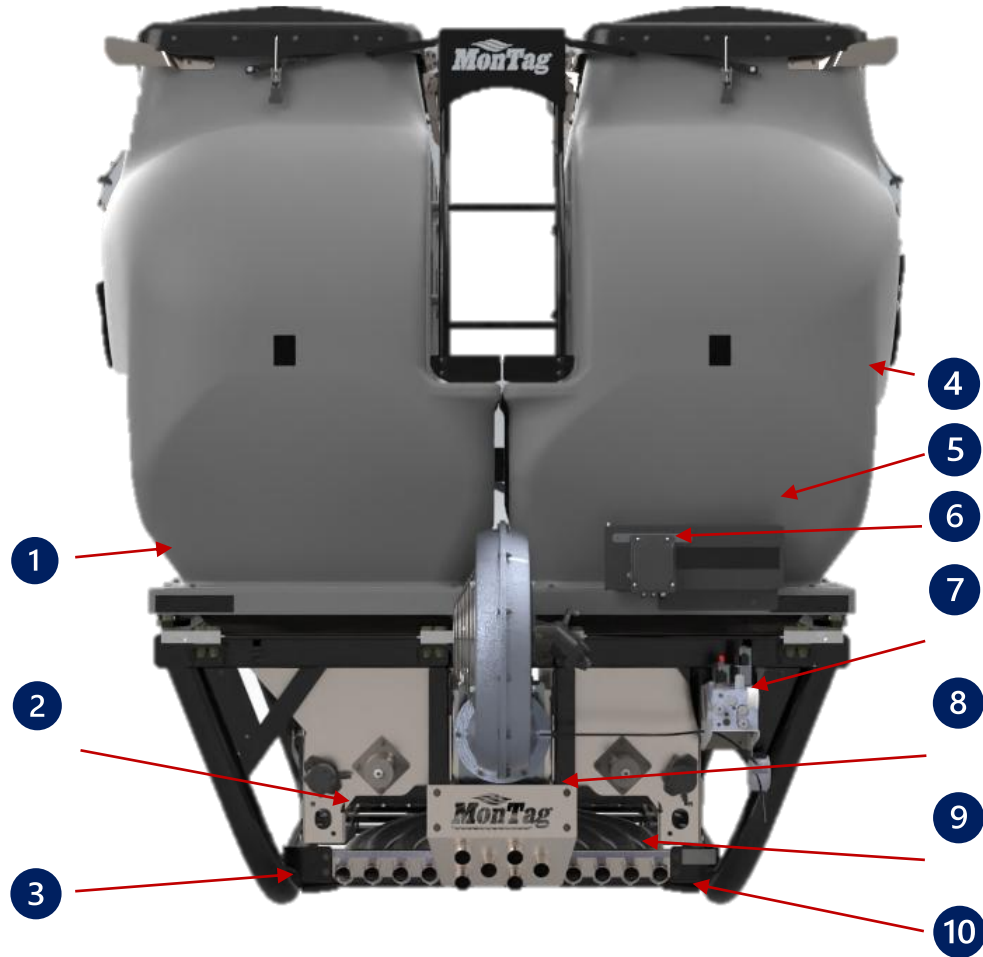

1	Hopper 2	6	Scale ECU
2	Slide Gate Cylinder 2	7	PWM Valves
3	Motor Encoder 2	8	Fan Pressure Sensor
4	Hopper 1	9	Slide Gate Cylinder 1
5	Montag Meter ECU	10	Motor Encoder 1

The following diagram shows how the Dry Rate Controller is structured on a **Gen 1**



1	Section 2 PWM Hydraulic Valve	5	Section 1 PWM Hydraulic Valve
2	Section 2 Encoder Motor	6	Section 1 Encoder Motor
3	Scale ECU	7	MDRC
4	Fan Pressure Sensor		

## Information On Identification Label

Adhered to the ECU is an Identification Label. The decal provides a unique ECU identification.

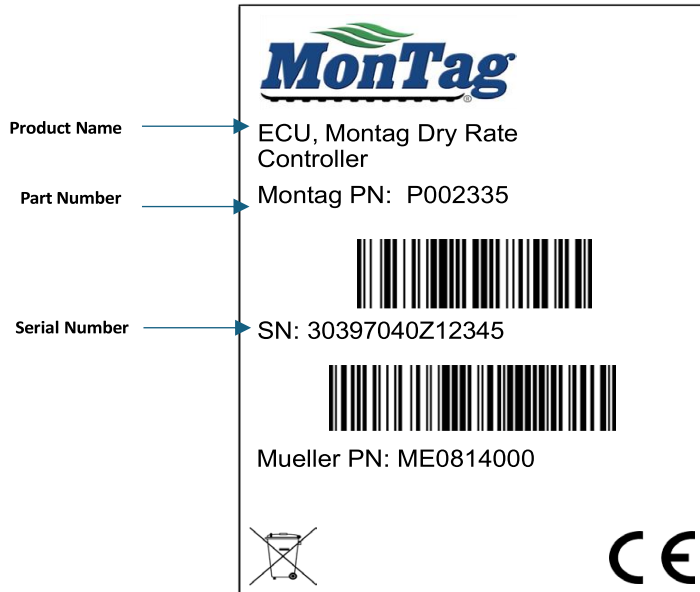

## About the Operating Instructions

### Who is the Target User for the Operating Instructions?

These Operating Instructions are intended for operators of the Montag Dry Rate Controller (MDRC) ISOBUS ECU from PTx Trimble/Mueller.

### Scope of the Instructions

These instructions describe all the functions that can be actuated with the ECU. This means that some chapters may not be relevant for the operation of certain implements.





### Directional Information in the Instructions

All directional information in these instructions, such as “left”, “right”, “forward”, “back”, is relative to the movement direction of the vehicle.

## Layout of Operating Instructions

The operating instructions explain step by step how to perform certain operations with the product.

We use the following symbols throughout these Operating Instructions to identify different operating instructions:

Type of depiction	Meaning
1. 	Actions that must be performed in succession.
	Result of the action - This will happen when an action is performed.
	Result of an operating instruction - This will happen when all steps have been completed.
	Requirements - If any requirements have been specified, these must be met before an action can be performed.

## Basic Control Principles

### Powering Up the ISOBUS ECU

Switch on the MDRC as follows:

1. Supply the ECU with power. This can be done in the following ways:
  - a) For ISOBUS tractors: Switch the tractor on using the ignition key.
  - b) For non-ISOBUS tractors: Switch on the display.

2. The MDRC is on.

3. Find Montag icon on UT Page





### Powering Down the Implement

Always switch off the implement in the following situations:

- When work is finished.
- Before leaving the field.

Switch off the implement as follows:

1. Switch application off by pressing the Master icon.  
-  The application indicators beneath the icon of the implement are grayed out.
2. Activate Road Mode by pressing the Hydraulics icon, followed by the Road Mode icon.



3. Shut off hydraulics controlling the Montag Implement
4. Switch off the tractor at the ignition switch and ensure that the display is switched off.
  -  The ECU is off.

## Road Mode Feature

Road Mode is available for Gen 2 only and should be used whenever transporting the Montag implement to and from the field. This status disables all applications and puts the control system in a state for out-of-the-field travel. This prevents product from becoming packed around the augers and causing shear couplers to break due to vibration from road travel.

When entering Road Mode, the machine will automatically close the hopper slide gates, once the gates are closed the meters will turn at 35% PWM output for 10 seconds to remove any remaining material from the meters. Confirm all sections are in the **BLUE** state. If it is in overlap or if the sections are turned OFF manually, sections will not turn ON when running the cleanout process. This may result in the output becoming plugged.

If the gates do not close completely a warning message will appear showing the following:

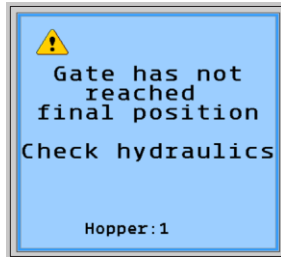

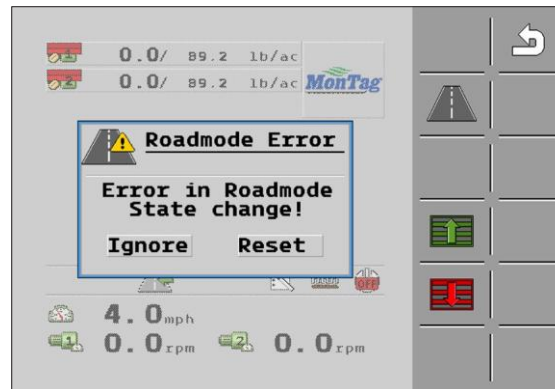

After acknowledging the warning, a pop-up window will show:



Road Mode functions only with hydraulic cylinders on Gen 2 machines.

## Browsing Between Screens

There are function icons that will advance to the function screen desired.

	Pressing the back arrow icon returns to the previous screen. There are some screens that have too many functions to display them all on one screen. To advance to the next page press the arrow.
	The three dots icon indicates another product or hopper screen. Pressing this icon also to toggle between Tank 1 & Tank 2 parameters.

# Gen 2/ Fortifier Run Screen

The Run Screen is always displayed during work and contains the most important information. The run screen shows the status of the MDRC System. Depending on the implement equipment, not all the icons are always shown. The Run Screen is divided into 9 areas.

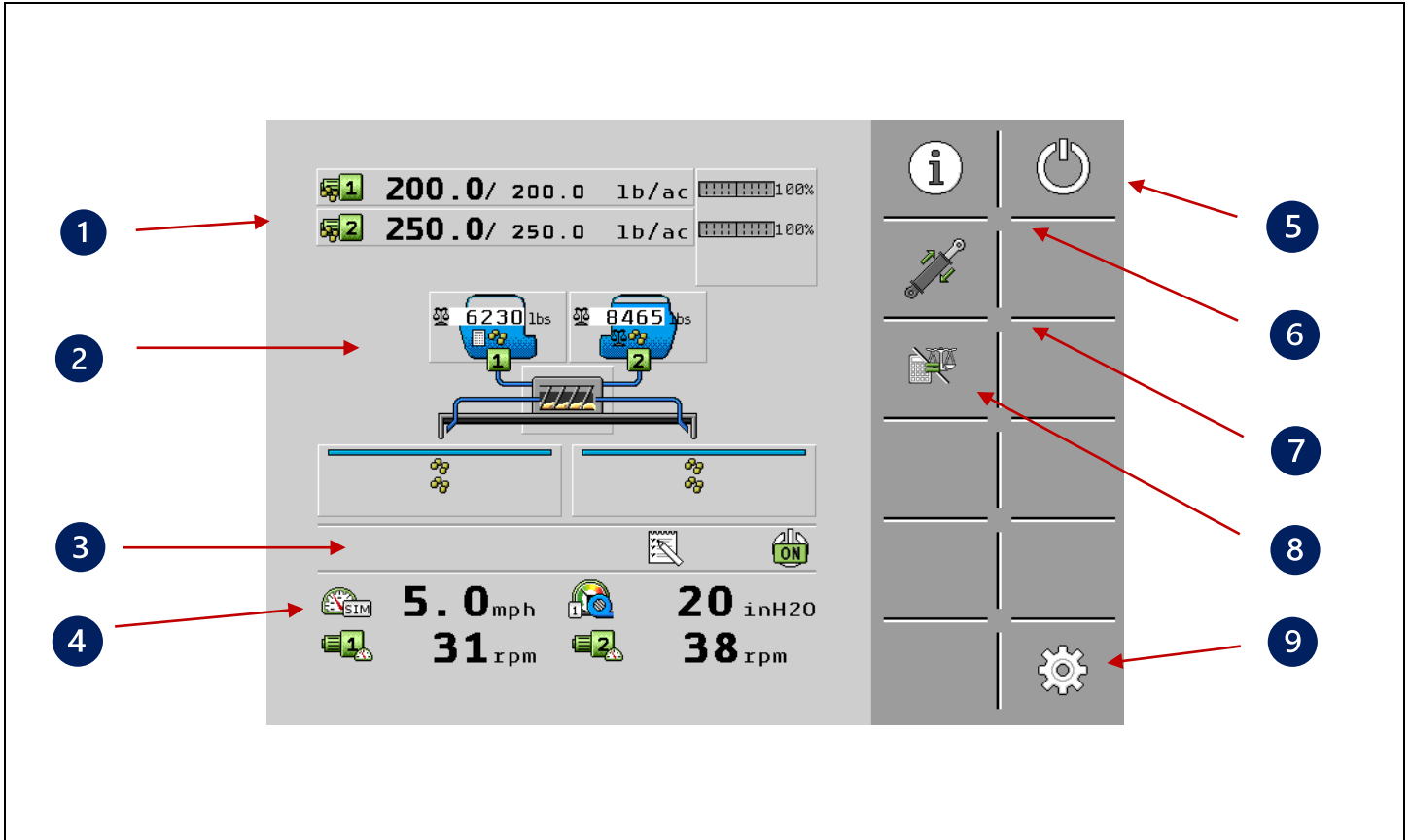

<b>1</b>	Hopper Target/Actual Rates	<b>6</b>	Results Softkey
<b>2</b>	Dry Rate Controller Display Area	<b>7</b>	Hydraulic Softkey
<b>3</b>	Status Line	<b>8</b>	Weight Equalizing Softkey (displays only at 0 MPH)
<b>4</b>	Visible Values	<b>9</b>	Settings Softkey
<b>5</b>	Master On/Off Softkey		

# Hopper Target / Actual Rates

This area displays information on the Target Rate, Actual Rate, and the Delta Target being applied.

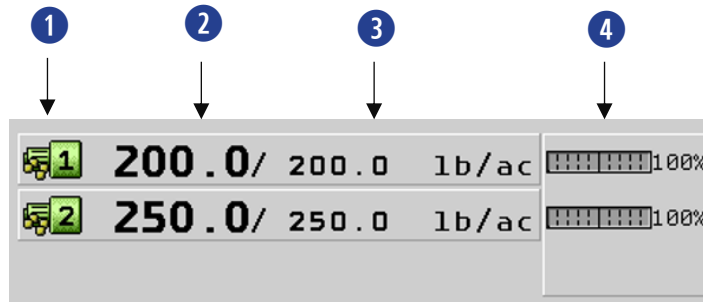

<p><b>1</b></p>	<p><b>Metering Drive Number</b> These icons indicate the number of drives that are set up in the system.</p>	<p><b>3</b></p>	<p><b>Target Rate</b> This area will display the current Target Rate as set by operator or by Rx.</p>
<p><b>2</b></p>	<p><b>Actual Rate</b> This displays the actual As Applied rate</p>	<p><b>4</b></p>	<p><b>Delta Target Rate Level</b> The bar graph provides feedback for the Delta Target Rate or by prescription.</p>

Meter Drive Icons	Description
	Gate fully open with a solid granular product type assigned to the meter.
	Gate fully closed
	Gate partially open and calibrated.
	Gate partially open with no calibration factor. <i>(Possible failed sensor)</i>
	Gate fully open with no calibration factor
	Gate partially opened with the meter turned off.
	Gate fully open and being controlled by a prescription with a seed product type assigned to the meter.

## Dry Rate Controller Display Area

This area of the Run Screen provides feedback on Dry Rate Controller operation.

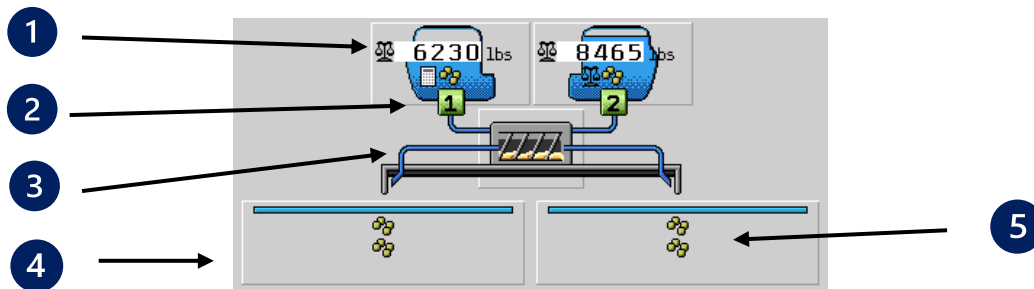

1	Hopper Weight - customer defined: actual or calculated
2	Hopper Number
3	Prime button to fill auger
4	Section ON/OFF Indicator - <b>BLUE</b> = sections on, <b>GREY</b> = sections manually off, <b>RED</b> = sections turned off by section control
5	Product Type - seed or solid

## Hopper Info

Each hopper can be pressed to show/edit detailed information. This feature works whether the Master is on or off, regardless of ground speed or if meters are applying product or off. This information includes product name, product density, product calibration, weight (scale, if installed, and virtual), and target rate.



To set the virtual weight equal to the scale weight, press the weight equaling soft key.  This should be done each time after filling the hoppers. Note that the tractor must be stationary to perform this task. When the weights are zeroed, and product has been applied, and the scale weight and the calculated weight should remain with 50 lbs. of each other. If spread gets greater a calibration may be necessary.

## Status Line

The following information is shown in this area.

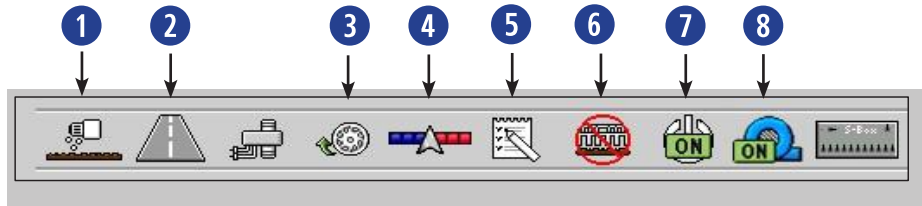

1	Active Calibration - displays when calibration is active ( <i>when 'no catch test' is selected</i> )
2	Road Mode indicator - displays when the system is in Road Mode
3	Prime indicator - displays when the auger is being filled
4	Section Control indicator - displays when Section Control is active
5	Task Controller indicator - display when using Task Controller
6	Work Position - displays the status of the implement ( <i>red line means inactive &amp; the implement is raised</i> )
7	Master ON/OFF indicator - displays the status of the Master switch
8	Fan indicator - displays the status of the fan

## Section Control

This symbol will be shown in the Status Line when automatic section control from the TC (Task Controller) is enabled and is controlling the application on and off function. As the machine crosses previously applied areas and borders, it will turn off application.

## Visible Values

The following information is shown in this area.

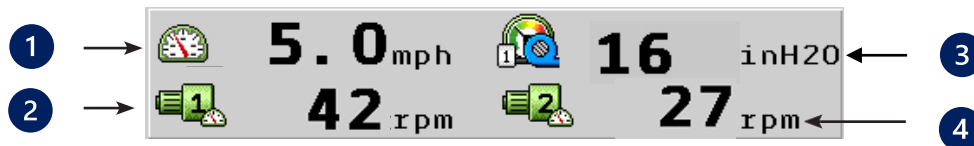

If there are more than 4 items set up in the Visible Values, press the visible values button shown previously to cycle through and see the additional items.

1	Speed Source and MPH
2	Auger 1 RPM
3	Fan Pressure
4	Auger 2 RPM

To configure the Dry Rate Controller Display area, Status Line and Visible Values, refer to section Run Screen Configuration.

## Run Screen

The Dry Rate Controller area of the Run Screen is slightly different for the different configurations. The functionality of the software is the same, but the mask shows only the number of hoppers configured. This example is one product. The Controller will control up to 4 dry products.

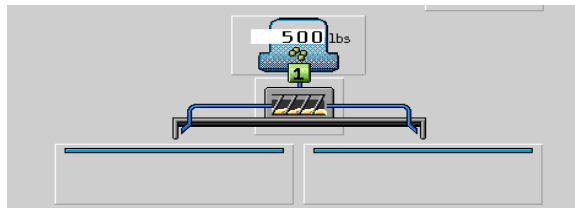

## Function Buttons

The function buttons are located on the right side of the screen. Each icon located on the function button depicts what the button is assigned to do.

	Sections Master Switch - Starts applying. The Regulation loop is active.
	Results Icon - Tracks how much of each product has been applied. This shows only the products that are currently selected in the hopper. To find other products used, that product must first be selected to a hopper.
	Hydraulics - Tap the icon to access the Function Buttons that control hydraulic operations.
	Road Mode - Activates Road Mode when pressed for transporting the implement. Refer to implement manual for operating instructions.
	Gate Open - Tap the icon to open the gate incrementally. Press and hold the icon to open the gate completely.
	Gate Close - Tap the icon to close the gate incrementally. Press and hold the icon to close the gate completely.
	Succession Hopper Switch - This icon appears on the Run Screen when the hopper succession is setup. Pressing the icon will manually switch the bins (turn bin 1 off, turn bin 2 on, and vice versa).

# Settings Screen

Pressing the Setting icon on the Run Screen brings up a second page with 7 different areas to adjust settings.

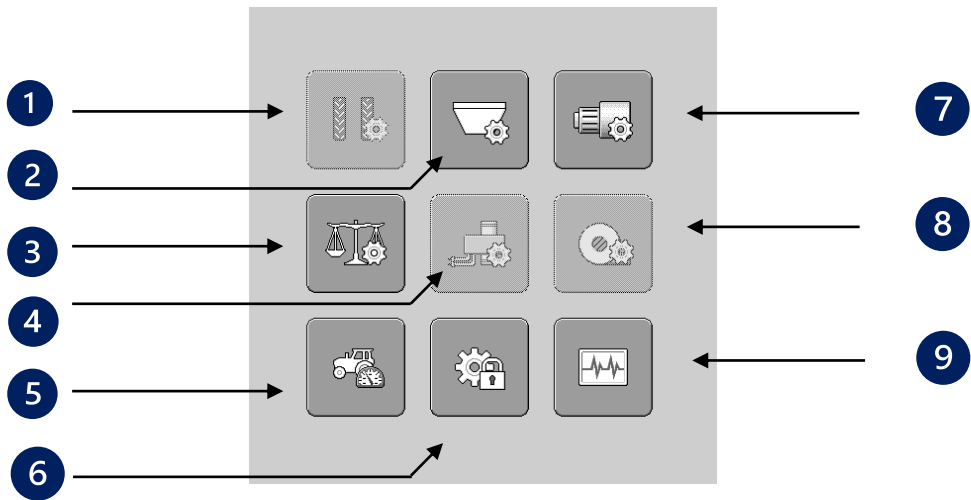

1	Not Used	6	Configuration Settings
2	Hopper Settings	7	Metering Drives Settings
3	Weigh System Settings	8	Fan Settings
4	Not Used	9	Diagnostics
5	Speed Source Settings		

## Hopper Settings

The Hopper Settings page allows selection of the product for each hopper, density, selection of shoot, hopper chaining, and enable or disable a hopper.

To access the Hopper Settings from the Run Screen



### **Choosing a Product for a Hopper**

To choose or change a product for a hopper, tap the selectable area under Associated Product. Select the product from the pop-up menu and tap the checkmark or make the selection (dependent on the UT display) to save the selection. Selecting a product for a hopper will update the meter settings for the meter assigned to the hopper. To change or add a product to the menu, see the Product Configuration section.

### **Set Current Hopper Weight**

The user can use a virtual hopper if the applicator is not equipped with a scale. In implement configuration page set weigh system to no. Then in hopper settings page touch the weight on the hopper and enter the current weight value. This weight will be decremented by the application rate applied. A weight is not required, but the virtual hopper weight will also trigger hopper changes for bin chaining and hopper level alarms.

### **Density**

Press the selectable area under Density to enter product density as measured by density scale provided by Montag Mfg. with the machine.

### **Associated Shoot (Distribution Channel)**

To assign a shoot to each hopper, tap the selectable area under Associated Shoot. Select the number of the shoot from the pop-up menu to assign it to the hopper number listed above that number on the screen. Tap the checkmark to save the selection. If more than one hose at a drop point on toolbar, then second hose becomes shoot 2. If only 1 shoot, then this selection is hidden.



### **Hopper Chaining**

This feature is used to link hoppers together and is sometimes referred to as *bin chaining*. This would apply when running a single product in multiple hoppers. The machine would then change from an empty hopper to a full hopper automatically while in working mode (sequential) or empty the chained hoppers simultaneously (parallel). The factory default for this option is set to Parallel, where both hopper auger at the same time. The Hopper Chaining Type can be changed with the OEM password in the locked section under implement configuration page.

*(If chaining a bin, then both hoppers to be chained must have the same product assigned or the system will issue a warning. The screen will update, and the user will only have one target rate for both hoppers. A visual chaining indicator will appear on the Run Screen for chaining as well.)*

Note that chained hoppers require the same shoot.

### Sequential Hopper Chaining

This option automatically changes metering from 1 hopper to metering from the next assigned hopper. This occurs once the Virtual Hopper Weight or Scale Weight reaches 5% of the set capacity of the hopper, or the system reaches the Low-Level Threshold value that the user has configured.

To set this up, the operator would choose a hopper to be unloaded first then make the next hopper the succession hopper.

Tap the selectable area under Succession Hopper to link the hoppers. Select the hopper number from the pop-up menu and tap the green check- mark to save the selection. Notice the hoppers are now visually linked on the Run Screen, as well as in the Hopper Settings Screen.



The Succession Hopper Switch softkey appears on the Run Screen when the hopper succession is set up. Pressing the icon will manually switch the bins (turn bin 1 off, turn bin 2 on, and vice versa).



### Parallel Hopper Chaining

The Parallel Hopper Chaining method will chain hoppers so that they will run together and empty at the same time. The amount of product ran from each hopper meter will be indicated by a percentage value visible in the Meter Settings screen. The percentage is based on the percentage of the total current weight in the hoppers. Both hopper meters will run to achieve a single target rate, but each meter will run at the percentage assigned based on the volume in each hopper. The meters assigned to these bins will all be set to the same rate. When hoppers are chained together using Parallel Chaining, only one set of Target Rates is adjustable. The Target Rate on the other metering drive will be greyed out and will update automatically. The target rate is the combination rate coming from both hoppers. The operator can still adjust the percentage for this value, if needed, in the Meter screen. The % values will default based on the amount in the 2 hoppers. For example, if 5000 lbs. in hopper 1 and 6900 lbs. in hopper 2.

Hopper capacity/total of 2 hoppers = % for each hopper  
 $5000/11900 = 42\%$

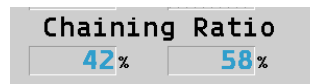

When refilling chained hoppers, ensure to press the Parallel Chaining soft key. This feature will come up with a ratio

to empty both bins simultaneously for each load



### Hopper Enable/Disable

Tapping the Hopper On/Off soft key will stop the meters assigned to the hopper indicated.



### Scale Weight & Virtual Weight

	<p>Pressing this icon allows users with scales to set virtual weight. The icon is only available when the unit is stationary (less than .6 MPH) and will set the virtual weight to match the scale weight. This is the only way to change virtual weight for machines using scales. <b>After filling the hoppers, the weights should be synced to allow proper weight/rate calculations.</b></p>
	<p>Pressing this icon will toggle between scale weight and virtual weight. Hopper weight can be viewed on the Run Screen, on the Hopper Settings page, and on the Weight System Settings page.</p>

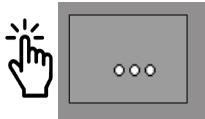

Press the three dots softkey to move to the next screen and set up these parameters for any additional hoppers that have been configured.

## Metering Drive Settings

The Metering Drive Settings allow the setting of the Target Rate, entering the calibration factor for each hopper, and setting up the Delta Target Rate.

Configure or view the following parameters for each metering unit:

Metering Unit	Defines the currently selected metering unit.
Target rate	Defines how much volume of product should be applied per acre for a manual rate.
Calibration Factor	Defines how much volume of product is applied per rotation of the metering shaft.
Target Rate Increment	Defines what percentage the target rate should be changed when changed manually during the application.
Chaining Ratio	Defines the percentage of products being applied from each chained hopper. <i>The % values will default based on the amount in the 2 hoppers.</i>

To access the Metering Drive Settings from the Run Screen

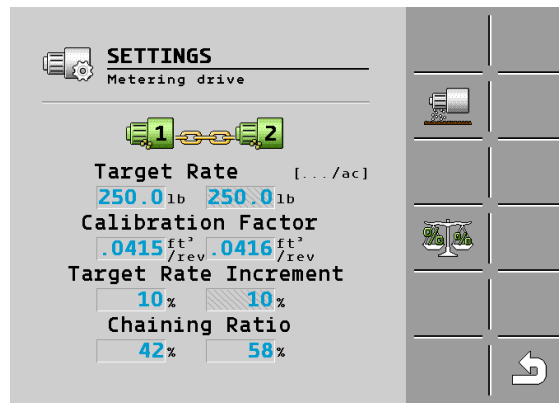

### Setting a Target Rate

To choose or change a Target Rate, press the selectable area under the Metering Drive. Type in the Target Rate. Press the checkmark to save selection. *Different product types may have target rates in various units. Ensure the correct value is entered for the unit type.* Note that when hoppers are chained together using Parallel Chaining, only one set of target rates is adjustable. The target rate on the other metering drive will be greyed out and will update automatically.

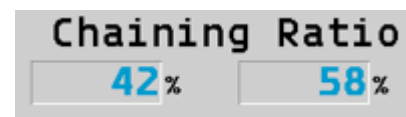
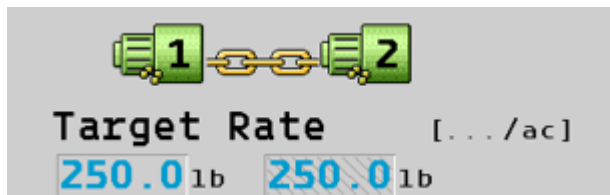

In the case above with bin chaining, the target rate of both hoppers is 250 lbs., though meter one will have a target rate of 105 lbs. (42% of the total target rate) and meter two will have a target rate of 145 lbs. (58% of the total target rate). When running prescription, the target rate will adjust automatically by the prescription map applied. The prescription is entered into the monitor (task controller) and sends rate through ISOBUS to the rate controller.

# Metering Drive Calibration

To operate the machine accurately, the user must calibrate the product type to the hopper. To do this, the working width of the implement must be defined in the Shoot Configuration Screen; there is then a calibration procedure that needs to be followed. This process must be done any time a new product is added to a hopper that hasn't been calibrated. Note that the type of meter calibration must be set up in the metering unit configuration screen.

Calibration Factor:

Below are starting calibration factor numbers for various machines.

MACHINE TYPE	CAL/ROW	NUMBER OF ROW MACHINE					
	FT <sup>3</sup> /ROW	8	9	12	16	18	24
GEN 1 STANDARD OUTPUT (2" HOSES)	0.0016	0.0128	X	0.0192	0.0256	0.0288	X
GEN 1 HIGH OUTPUT (2.5" HOSES)	0.0032	0.0256	X	0.0384	0.0512	0.0576	0.0768
GEN 2	0.0026	0.0208	X	0.0312	0.0416	0.0468	X
FORTIFIER	0.0026	X	0.0234	0.0312	X	X	X
2108	0.0026	0.0208	X	X	X	X	X
2208	0.0026	0.0208	X	X	X	X	X
Low-Rate Auger							

To find the Cal. Factor when using ft<sup>3</sup>/Rev, multiply the number of outputs by .0026. (For this example, using a Gen 2 model, this number may need to be adjusted by product or environment change.)  
 ft<sup>3</sup>/Rev Example: 12 outputs X .0026 = .0312



Note: The four methods to conduct a Meter Calibration are Catch Test via Amount, Field Run, Catch Test via Acreage, & Catch Test via 1000ft. Field Run calibration is the most used type of calibration and set as default in metering unit configuration screen.



This soft key will appear when the user has selected any of the catch test calibrations for a meter in the Metering Unit Configuration screens and will take the user to the Calibration screen to select the meters they wish to perform a calibration on.



This soft key will appear when the user has selected a field run calibration type for a meter in the Metering Unit Configuration screens and will take the user to the Calibration screen to perform the calibration on the meters that have been selected for a field run calibration type.

## Field Run Calibration

Meter Calibration can be done in the field while applying product if using a scale system.

To do this, there is a calibration procedure that needs to be followed. This process must be done any time a new product is added to a hopper that hasn't been calibrated.

- Verify the product name in the hopper is correct.
  - Verify the product density is correct.
  - Verify the correct CRF.
  - Enter Target Rate that will be simulated.
  - Vehicle will need to be stationary at the start of the calibration. Stop tractor on level ground and have toolbar lower.
  - Enter Calibration by directions below.
  - Run normal application of 250-1000 lbs. Section control and prescriptions can be used.
  - Confirm the Master Switch is on and sections are enabled. If not, a warning message be displayed and the calibration will not start.
  - To complete calibration, the tractor must be stopped again on level ground with toolbar lowered to ensure a good reading of the scale.
1. The accuracy of the Montag Air Cart depends on using the correct Calibration Factor. This value is for the entire implement width.
    - a. To find the Cal. Factor when using ft<sup>3</sup>/Rev, multiply the number of outputs by the correct Cal # from the chart. (This number may need to be adjusted by product or environment change).
      1. **ft<sup>3</sup>/Rev Example Gen 2: 16 outputs X .0026 = .0416**
    - b. To find the Cal. Factor when using Lb./Rev, multiply the number of outputs by .0026 times the density. (This number may need to be adjusted by product or environment change).
      1. **Lb./Rev Example: 12 outputs X .0026 X density (70) = 2.184**
  2. Type in the Calibration Factor. Press the checkmark to save selection. Notice the example is set as ft<sup>3</sup>/rev. This is operator configurable by following directions in Product Configuration.





3. To begin

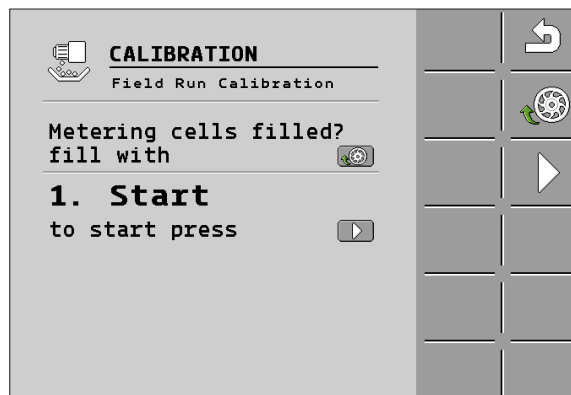

- The Calibration screen will be displayed.



4. Start hydraulics and set the operating hydraulic pressure by the fan air pressure reading.
5. Fill the metering cells with product.
  - The metering cells rotate for a few second: 
6. Make sure the tractor is stationary and start the calibration by pressing the play icon. 
7. Return to Run Screen. Start applying product in the field as normal. It is recommended to run 1,000 lbs.
8. Stop application of the product and return to calibration menu. Fan must remain running at the same pressure as when calibration started. 
9. The Calibration 2 screen displays both the scale amount applied, and the calibrated amount applied during the calibration. Press the checkmark

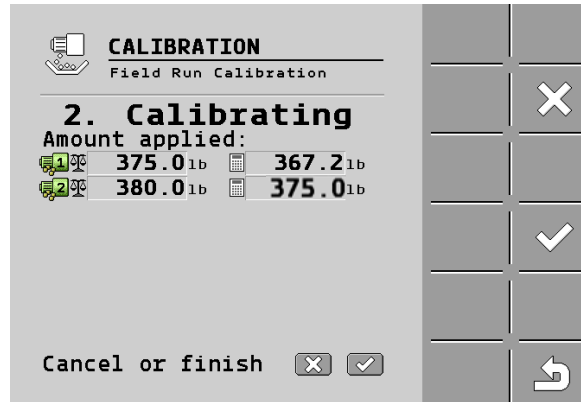

10. → The Calibration 3 screen appears.

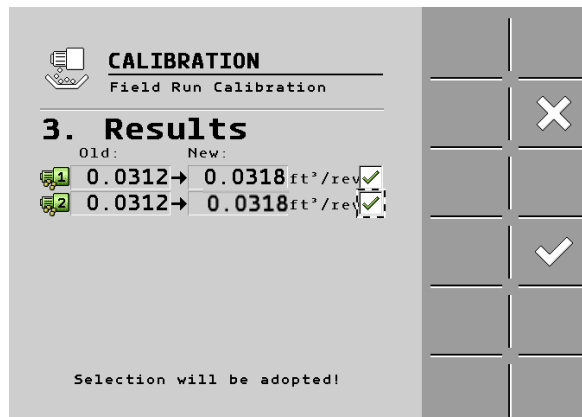



11. Select the new calibration values for the meters that were suggested from the calibration by pressing the white box next to that value to place a green checkmark next to the meter calibration value.
12. Tap the checkmark to save the selections.
  - The ECU saves all the data on the product in the product database

## Catch Test via Amount

This method of calibration is common when the implement does not have scales. Catch Test calibration is initiated from the UT terminal. The user catches the volume discharged by the system based on the following settings:

Enter the target volume that will be simulated. Enter the target speed.

1. To begin the Calibration process, tap the Metering Drive softkey  

→ The Calibration screen will be displayed.

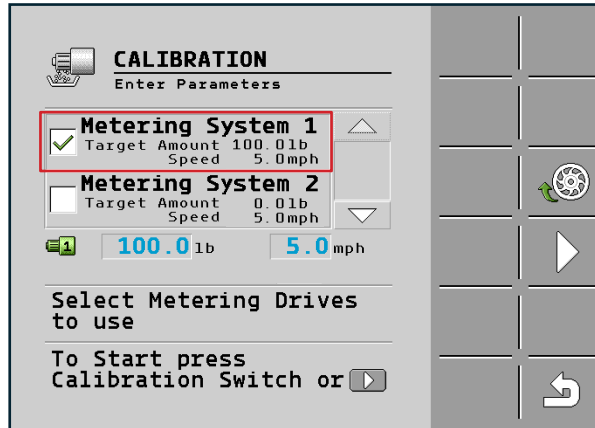

2. Select one Metering Unit at a time by pressing  the white box to place a green checkmark next to that metering system number and the metering system button. Ensure that the Target Amount and Speed parameters are showing up in that box. Ensure that the correct meter number is shown on the green meter icon.

3. Enter the total amount to catch and the speed for the test. Start hydraulics and set the operating hydraulic pressure by the fan RPM reading.

4. Prime the meter by filling the metering cells with product.



→ The meter turns for one (1) revolution based on current target speed and calibration factor and times out at 15 seconds. A flashing icon indicates that the prefill is in process.

5. Place a container (seed bag or bucket) under each discharge point. Make sure not to restrict air flow.

6. Start the calibration by tapping the play soft key.

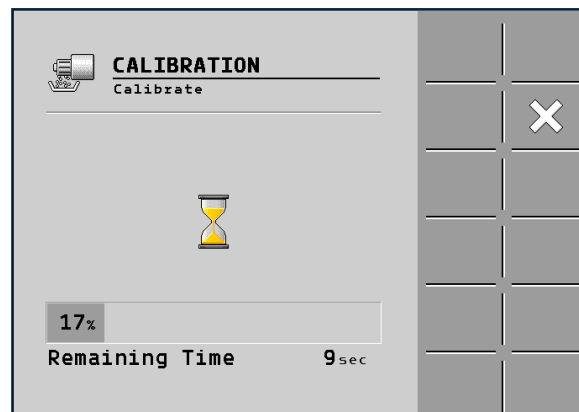

→ The Calibration 2 screen appears counting down the remaining time.

7. Wait until the required quantity has been applied. The ECU calculates a weight from the available data.

8. Stop the calibration on the implement. Shut-off hydraulics after the flow of product stops.

→ The Calibration 3 screen appears.

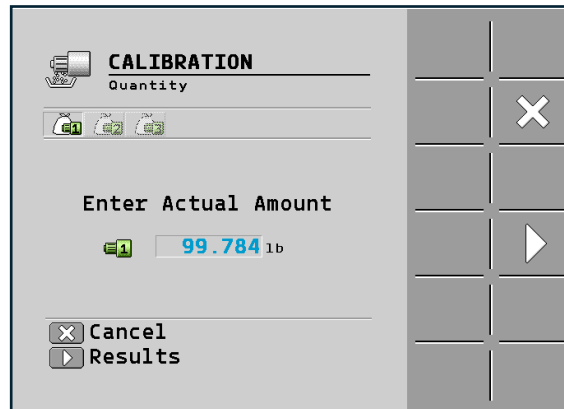

9. Weigh the product that was caught during the calibration.

10. Enter the total weight in the lb. field.

→ The Calibration 4 screen appears.

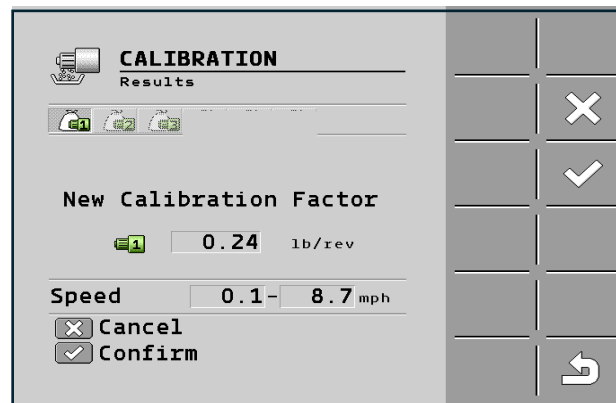

11. The meter speed range will be displayed, in addition to the new updated Calibration Factor.

12. Complete 2<sup>nd</sup> product by repeating steps 1 through 11.

**Catch Test via Acreage**

This follows the same instruction as catch test via amount with the exception that the number of acres is entered instead of pounds of product.

**Catch Test via 1000 ft.**

This follows the same instruction as catch test via amount except no amount is entered.

**Target Rate Increment**

The Target Rate Increment is the percentage or amount of adjustment of the Target Rate. This can be done using the Delta Rate Softkeys. This option is set up in the Product Configuration in the product database, setting the numeric amount of the rate change and the units. To choose or change the Target Rate Increment, tap the selectable area under Target Rate Increment. Type in the percentage of change desired to be made with each button press on the Run Screen. Tap the checkmark to save the selection. In the product configuration the rate increment can be changed from % to lb./ac.

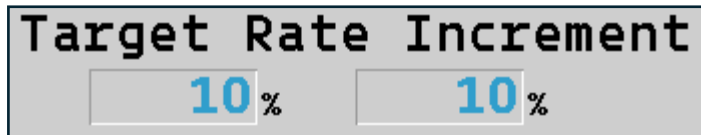

# Weigh System Settings



→ The Weigh System screen will be displayed.

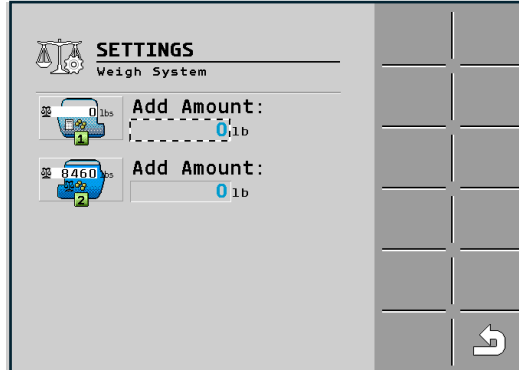

## For Filling

If a scale system is installed on the implement, use this procedure for the filling sequence:

1. Press the selectable area under Add Amount and enter the desired weight for the hopper.

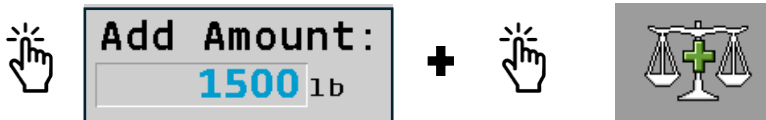

2. Fill the hopper. A warning message will be displayed when the entered weight is reached. Press the checkmark.



To reset the scale weight

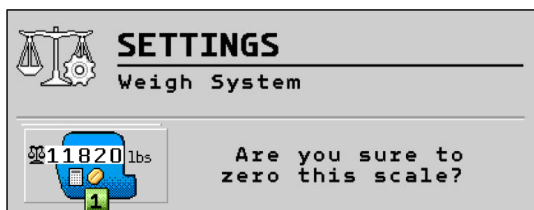

Or press X to cancel.

## Fan Settings

The Fan Settings allow the RPM output to be set for the fan. This is used with a Montag Fortifier or when using power beyond hydraulics. For other machines this will be grayed out.



Enter the desired fan RPM

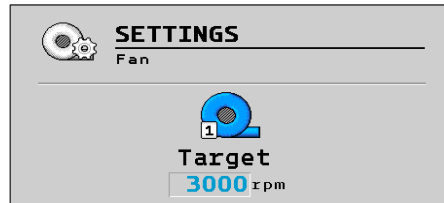

To start and stop the fan, press the Fan Power icon on the home screen. The task bar will show the state of the fan either on or off.

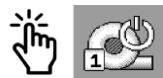

## For Power Beyond Applications

Contact your dealer to set controlling type to hydraulic Motor RPM.

## Speed Signal Settings

The Speed Input Settings allows the choice where the machine speed is coming from to control the application rate. There are different working speed sources and one simulated speed source. The Tractor and Implement speed on the display are in real time. If GPS is displayed on the ISOBUS, this will also be an option.

Speed Source	Description
Simulation	The speed is simulated by the display.
Tractor	The speed signal comes from the ISOBUS. Choose GPS if equipped with a tractor ECU.
Implement	The speed signal comes from a source on the implement

1. From the Run Screen

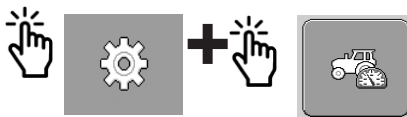

→ The Speed Calibration screen appears:

2. To select the desired speed source, press the white box to select the green check

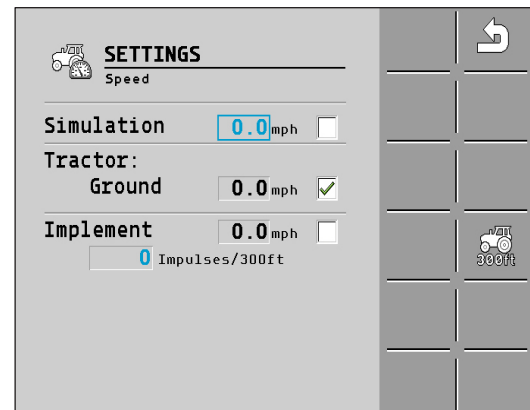

### **Simulated Speed**

The simulated speed source is used for troubleshooting purposes while not moving. To choose Simulated Speed, press the white box to enter a green check. Enter the desired speed by pressing the selectable area by MPH. Press the green checkmark to confirm. Simulation speed reverts to 0 after a power cycle but will remain the selected speed source.



### **Tractor Speed**

Tractor speed source gets the tractor speed off the ISOBUS. Some machines will have this speed on the bus and other machines will have the ability to use GPS for Speed.

To choose Tractor Speed, press the white box to enter a green checkmark

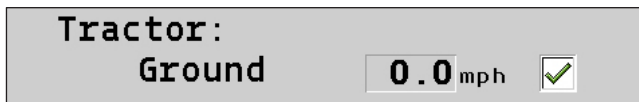

### **Implement Speed**

Implement speed source gets the speed from a pulse either from a wheel sensor or radar.

1. To choose Implement Speed, press the white box to enter a green checkmark.
2. To manually enter a pulse setting, enter the desired speed by pressing the selectable area by MPH. Press the green checkmark to confirm.
3. To calibrate the implement speed, press the Tractor 300 ft. 

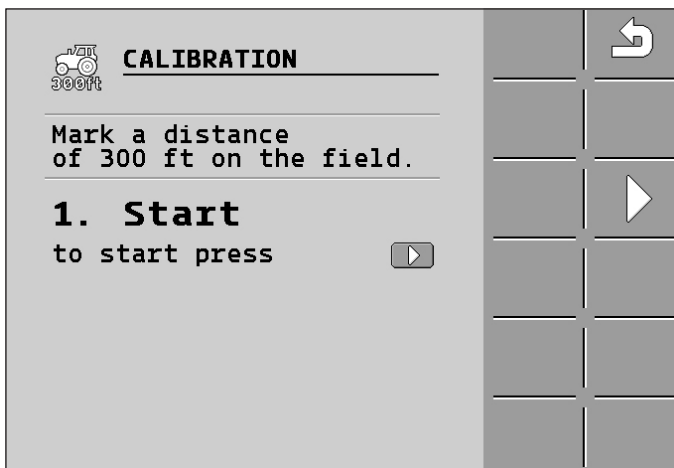

4. Mark a distance of 300 ft. Press the Play icon and drive the tractor 300 ft.



→ The following screen appears

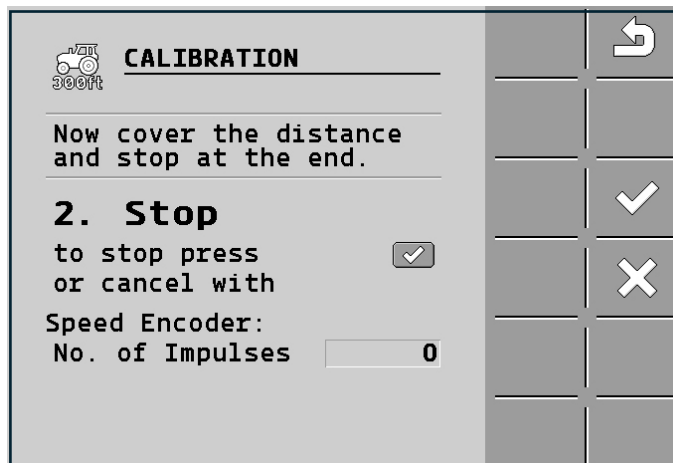

5. Verify movement of 300 ft.

6. Press the Check Mark to save the calibration value.



7. Enter the number of pulses.

# Configuration Settings

The Configuration Settings allow the setup of different aspects of the control system.



→ The Configuration screen will be displayed.

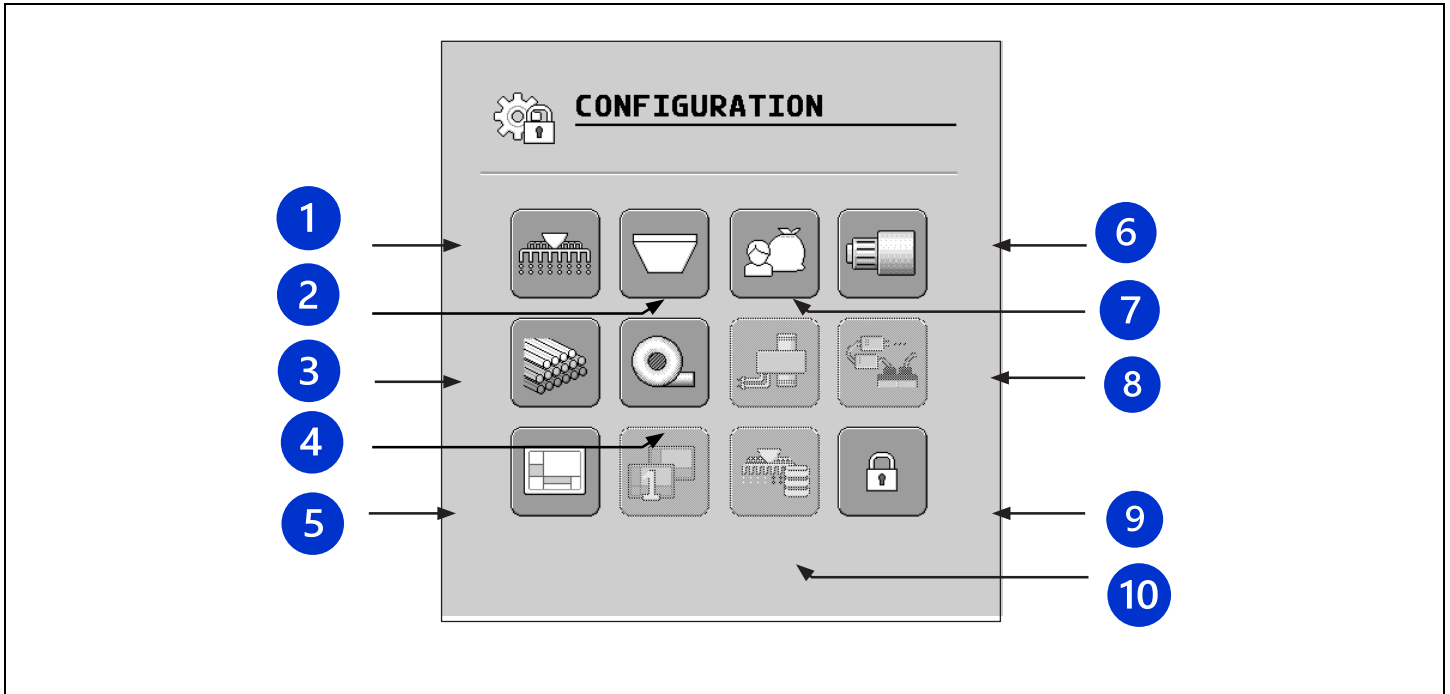

1	Implement Configuration	7	Product Configuration
2	Hopper Configuration	8	Not Used
3	Shoot Configuration	9	Locked Area
4	Fan Configuration	10	Profile Database Configuration
5	Status Line Configuration		
6	Metering Unit Configuration		

## Implement Configuration

Implement Configuration allows configuration of the Override Speed, Return Main Screen time, Manual Section Switching, Working Position, Weigh System, External Master Switch, and Device Class.

To access the Implement Configuration from the Run Screen



→ The Configuration screen will be displayed.

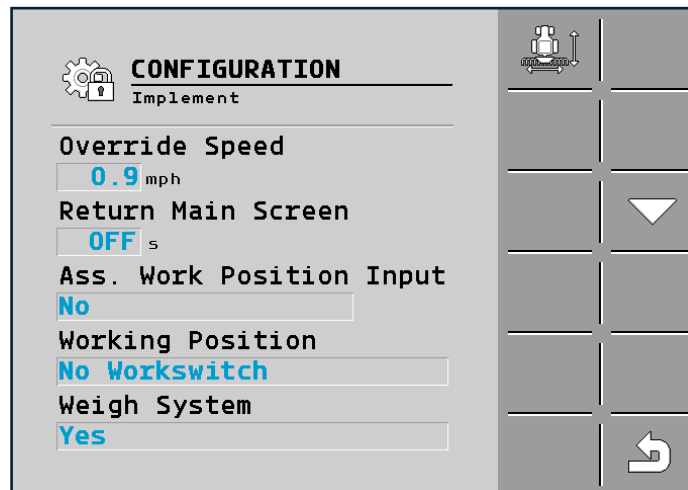

### **Override Speed**

The minimum controlled application point. At this speed, the rate will not go lower to prevent the system from reaching a level too slow to maintain.

### **Return Main Screen**

Amount of time the system will take to default back to the main Run Screen when the system is applying. Default setting is off, and operator needs to manual back to home screen.

### **Associated Work Position Input**

If using work switch set to work state input 2. If you are not using a work switch, set to no.

### **Working Position**

The Working Position allows the position of the Work switch to be configured. To setup the Work switch, press the selectable area under Work switch Position. Choose the desired option from the pop-up screen. Press the checkmark to save selection.

### **Implement Switch (Work Switch/Whisker/limit switch)**

1. Set Associated Master Switch Input to no.
2. Set Associated Work Position Input to Work State Input 2
3. Set Working Position as desired (typically Work switch ON in Work)
4. Test by raising and lowering toolbar and observing work switch Icon on task bar

Next, tap the down arrow for 2nd page:

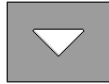

<input checked="" type="radio"/>	No Workswitch
<input type="radio"/>	Workswitch OFF in work
<input type="radio"/>	Workswitch ON in work
<input type="radio"/>	ISOBUS Tractor
<input type="radio"/>	Case IH Planter Status

→ The Configuration 2 screen appears:

**CONFIGURATION**  
Implement

Ass. Master Switch Input  
**Work State Input 2**

ext. Master Switch  
**No**

Ass. Meter Delay Input  
**No**

Device Class  
**Fertilizer**

### **External Master Switch (Foot Switch)**

When using a Montag footswitch

1. Set Ass. Work Position Input to No.
2. Set Ass. Master Switch Input to work state input 2.
3. Set ext. Master Switch to Momentary Switch

<input checked="" type="radio"/>	No
<input type="radio"/>	Momentary Switch
<input type="radio"/>	Latching (High in Work)
<input type="radio"/>	Latching (Low in Work)
<input type="radio"/>	Hagie Master Spray

If an External Master Switch is selected, the onscreen master softkey will be removed

### **For Hagie applications**

If connected to a Hagie, the "Hagie Master Spray" option may be selected to be operated from the joystick.

## Weigh System

The Weigh System selection allows the application to support ISOBUS Scale options for hoppers. When using a Digistar or Point ISOBUS scale system, set to yes.

Next, tap the down arrow:

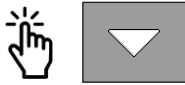

## Device Class

The user can select a Seeder/Planter or Fertilizer Device Class for the chosen application.

## Implement Geometry

The geometry of an agricultural implement is defined as a series of parameters describing its dimensions. It is important particularly for all systems that are GPS-controlled. The distance entered depends on whether the implement is towed, mounted on the tractor, or self-propelled.

Enter the distances for the boom and for the connectors. In doing so, ensure that the center point of the implement axle or pivot point is always the point of origin for all distances. Measurements towards the front are always negative, and measurements towards the rear are always positive. Using the application screen, the positive or negative offset values are handled for the user and are not needed to set up the shoot geometry.

To access the Implement Geometry from the Run Screen

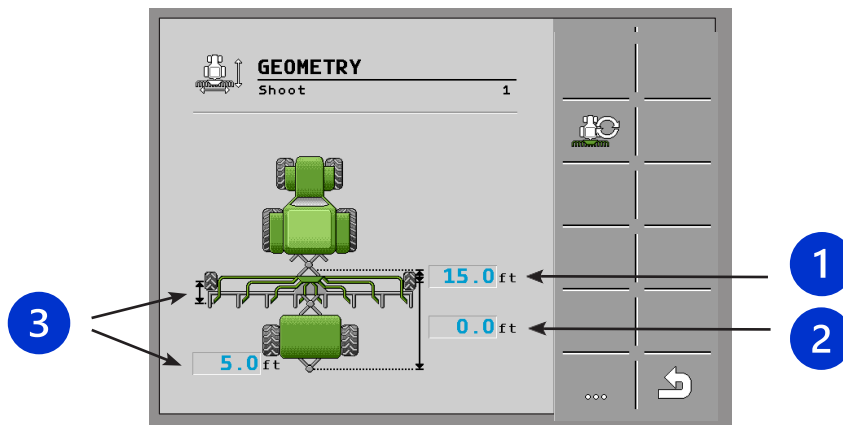

To enter the dimensions for the implement, tap the selectable areas on the geometry screen. Enter a new value and tap the checkmark to save the selection.

1	The distance in feet from the hitch-to-implement axle or the pivot point.
2	The distance in feet from the implement axle to the second connection point <i>if another application is attached</i> . This is set to default as a single connector. (If second connector is not configured, contact your Dealer)
3	Location of the application point in relationship to the implement axle or pivot point, depending on the machine setup selected the values are reported to the Task Controller Section Control module with correct + or - values.

To select a different implement setup than what is pictured, tap the Geometry Option soft key.



1. Use the left/right arrows to scroll through the tractor selection options.

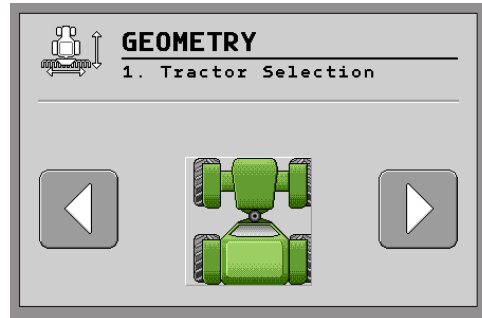

2. Once the correct tractor is visible on the screen, save the selection by tapping on the tractor button.  
→The Connector Selection screen will appear.

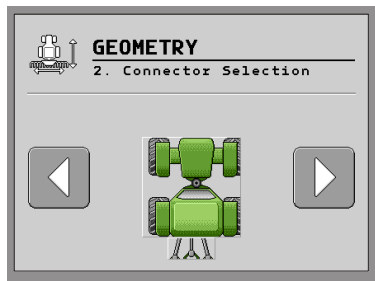

3-Point Hitch

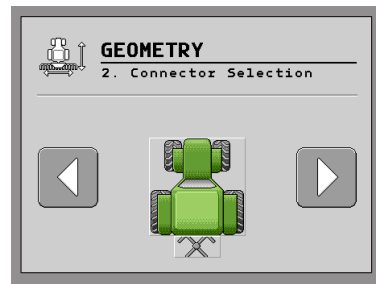

Drawbar Hitch

3. Use the left/right arrows to scroll through the connector selection options. Once the correct connector is visible on the screen, save the selection by tapping on the connector button.

→The Implement Selection screen will appear.

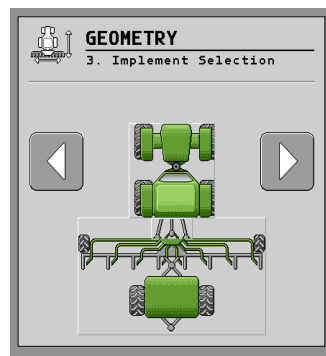

4. Use the left/right arrows to scroll through the Implement Selection options. Once the correct implement configuration is visible on the screen, save the selection by tapping on the implement button. This will cycle back to the main geometry screen.
5. Enter dimensions from hitch to center of tire pivot, enter dimensions from tire pivot to drop point. If pulling another product behind dry, enter from drop point to rear hitch.
6. Tap the soft key with three dots to move to the next shoot.



## Hopper Configuration

Hopper Configuration allows for setting the Associated Product, Low Level Threshold, and Virtual Hopper for a hopper.

To access the Hopper Configuration



→ The Configuration screen will be displayed.

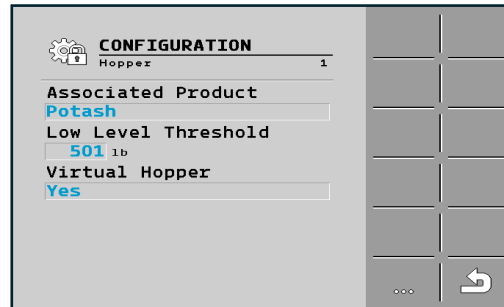

### **Associated Product**

Choose the Product from the pop-up screen and enter the correct weight. Press the checkmark to save selection.

### **Low Level Threshold**

The lowest amount of product the hopper can reach before the system issues an alarm. Also used in sequential bin chaining to switch from one hopper to the next when this low-level threshold is reached.

### **Gate Type**

If slide gate has internal sensors, select analog for both hoppers. If slide gate has a white sensor box on top of the cylinder assembly, select digital gate type for both hoppers.

### **Virtual Hopper**

The Virtual Hopper gives an approximate weight of product in the hopper based on the amount added to the hopper and the amount applied from the hopper. Choose Yes or No.

Press the icon with three dots to cycle through the hoppers.



# Shoot Configuration

Shoot Configuration allows the set-up of the number of sections/rows, total working width, and the number of meter outlets for the implement.

To access the Shoot Configuration



→ The Configuration screen will be displayed.

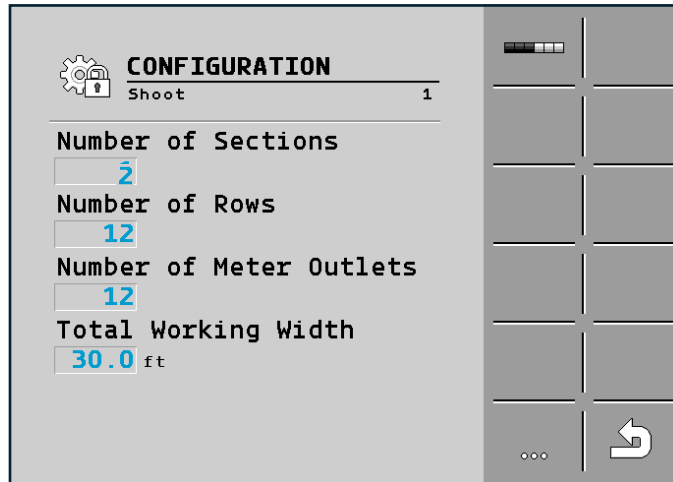

To make changes to the Shoot Configuration, press the selectable area under each parameter. Type the new value into the pop-up screen. Press the check-mark to save selection. Number of Meter Outlets is the number of hoses leaving the Montag. The number of Rows is the number of product drops. If using splitters, the number of rows will be larger than the number of meter outlets.

Press the icon with three dots to cycle through the shoots.



## Section Configuration

1. To configure the Sections, tap the Section soft key.

→ The Section Configuration screen will appear:

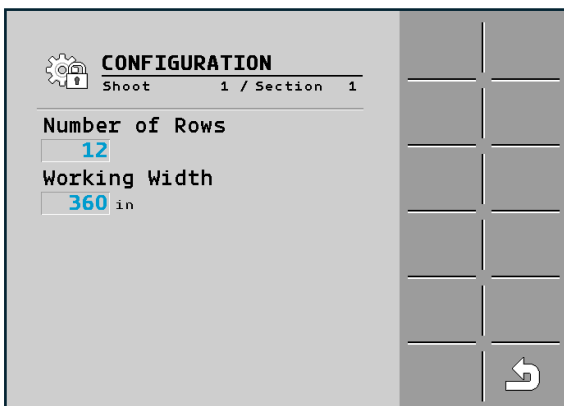
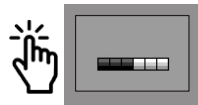

2. Enter values for each option by tapping the selectable area under each option, entering a new value in the pop-up menu, and tapping the checkmark to save the selection.

3. Press the icon with three dots to cycle through the sections for each shoot.



# Fan Configuration

The Fan Configuration settings allow a minimum/maximum motor speed to be set, and a pressure sensor to be set up for the fan.

To access Fan Configuration



→ The Fan Configuration screen will be displayed.

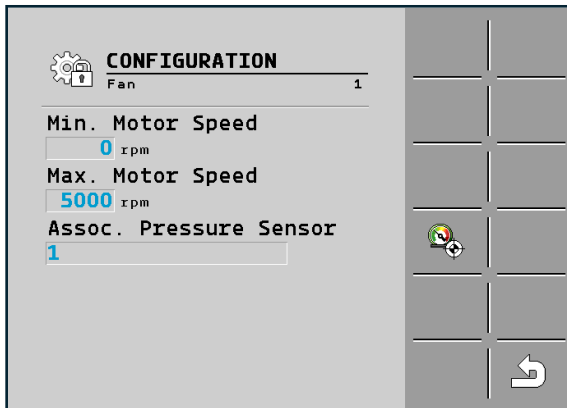

## **Min./Max. Motor Speed**

Allows manual setting of the minimum and maximum motor speed. This sets the alarm limits for initiating popup warnings.

## **Assoc. Pressure Sensor**

Allows the user to choose which pressure sensor is associated with the fan. Select "1" for the main fan. In case of sensor failure, this can be set to no to disable constant alarms. See Diagnostic section for troubleshooting pressure sensor.

## **Pressure Sensor Calibration**

1. Tap the Calibration soft key on the Pressure Sensor Configuration screen to calibrate the pressure sensor. Ensure the correct pressure sensor number is selected before performing the calibration.



This softkey will not be visible if the Associated Pressure Sensor option is set to No.

The Configuration 1 screen will be displayed.

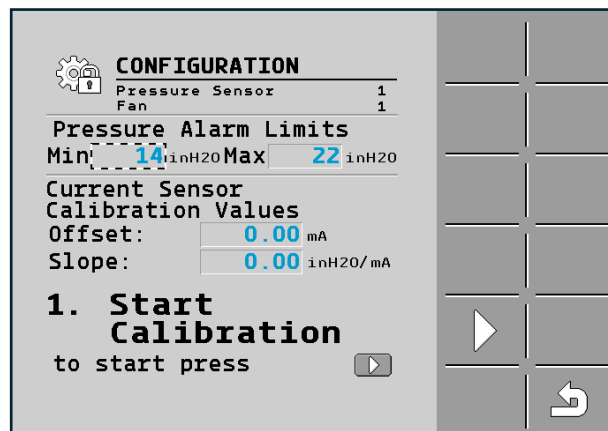

2. Enter the Min and Max Pressure Alarm limits. The offset and slope values will adjust during the calibration so they can be left blank.
3. Press the play icon to begin the calibration.
  - The Configuration 2 screen will be displayed

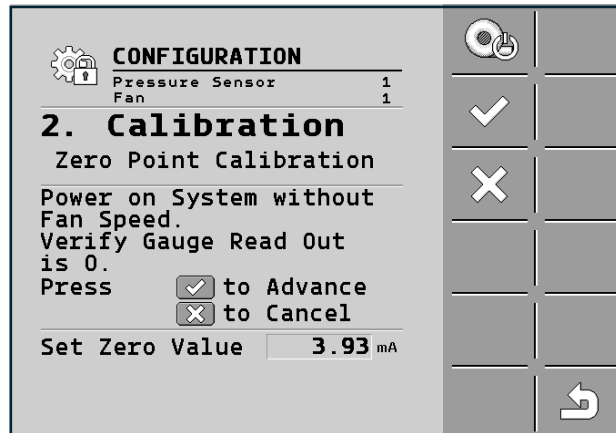

4. On the second calibration page the Set Zero Value will pick up the mA reading of the pressure sensor. The hydraulic fan must be off before pressing the checkmark. The mA range should be 3.9-4 mA.
  - The Configuration 3 screen will be displayed.

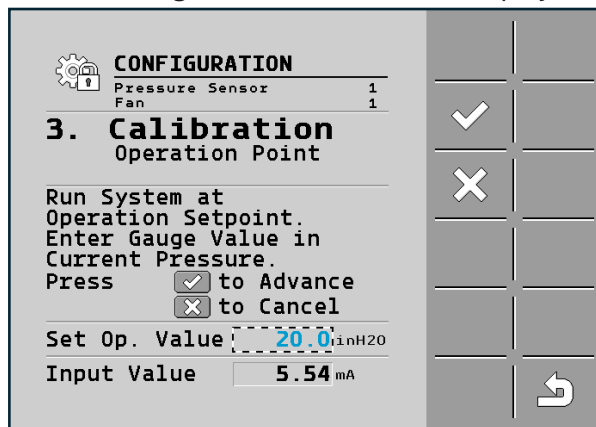

5. Turn the hydraulic fan on to approximately 20 inches to proceed. On the third calibration screen manually enter in the reading from the fan pressure gauge on the machine in the Set Op. Value area. Press the checkmark to complete the calibration.
  - The values are updated, and the calibration is complete.

## Run Screen Configuration

The Dry Rate Controller Display area, Status Line, and Visible Values on the Run Screen are configurable. To access the Run Screen Configuration from the Run Screen



→ The Run Screen Configuration screen will be displayed.

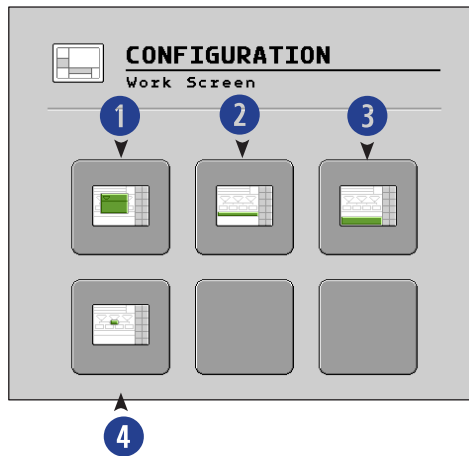

1	Hopper Info
2	Status Line area
3	Visible Values area
4	Center Icon Area

### Hopper Info Area

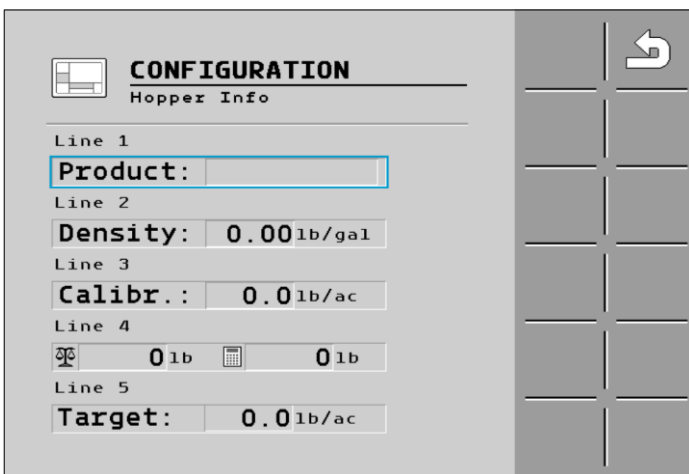

Selecting a line area allows the information to be reorganized.

### Status Line Area

To make changes, press the selectable area next to each position. Choose the status icon from the pop-up menu desired for the position. Press the check- mark to save selection.

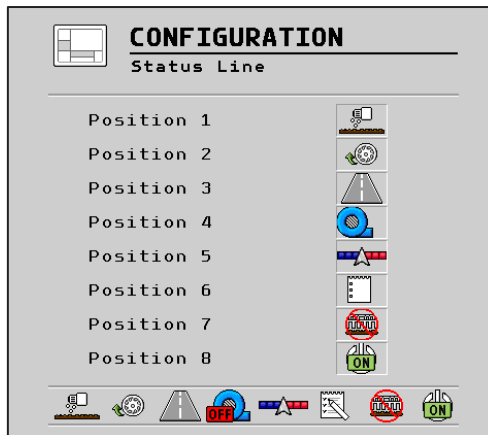

### Bottom Area

Press the selectable area next to each position. Choose the status icon from the pop-up menu desired for the position. Press the checkmark to save selection. To enter positions 5 through 8.

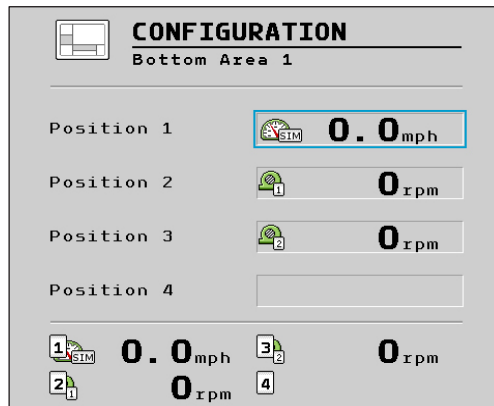

### Center Icon Area

Press the selectable area next to each position. Choose the status icon from the pop-up menu desired for the position.

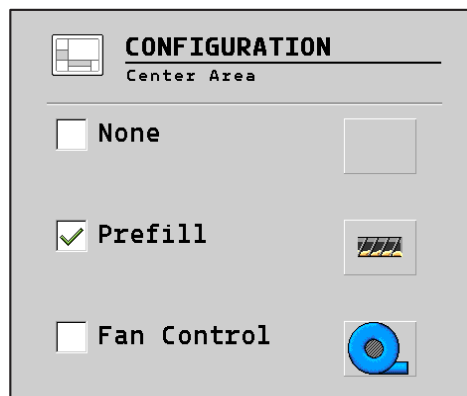

## Metering Unit Configuration

The Metering Drive Configuration allows set-up of the Target Rate, Deviation Tolerances, Min./Max. Motor Speeds, Prestart Time, Amplification Factor, Calibration Type, Section Control Delay, and PWM Resume.

To access the Metering Drive Configuration



→ The Metering Unit Configuration screen will be displayed.

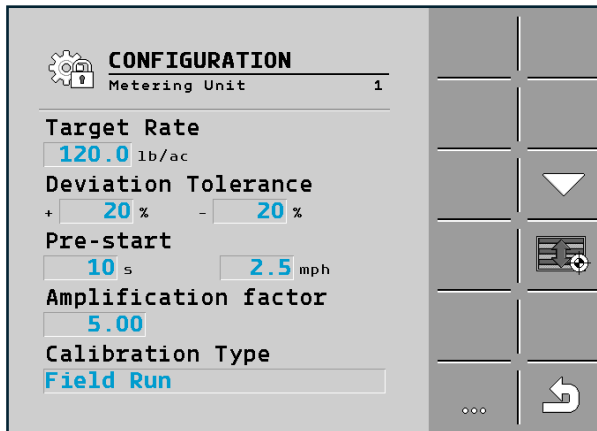

Press the selectable area next to the parameter to change. Enter a new value. Press the checkmark to save selection.

### **Target Rate**

Defines how much volume of product should be applied per acre.

### **Deviation Tolerance**

This parameter is for setting the alarm threshold for the Target Rate. If the applied rate varies outside the set Deviation Tolerance, the system will show an alarm.

### **Pre-start Time**

This Pre-start time setting adjusts the amount of time the auger runs when the system is primed or jump start. The MPH speed determines the rate the augers will turn. Both time and speed are user defined values.

### **Amplification Factor**

This Amplification Factor changes the control loop aggressiveness. Increasing the number makes the meter more aggressive. Decreasing the number makes the meter less aggressive. If the system is slow to reach the target rate, increase the number. If the meter struggles to hold rate by constantly overshooting, decrease the number.

### **Calibration Type**

Choose the type of calibration for the control system: No, Catch Test via Amount, Field Run, Catch Test via Acreage, and Catch Test via 1000ft. On the meter calibration screen, each metering unit will be set to run the calibration type set here. [→27]

Press the down arrow to move to the next screen.



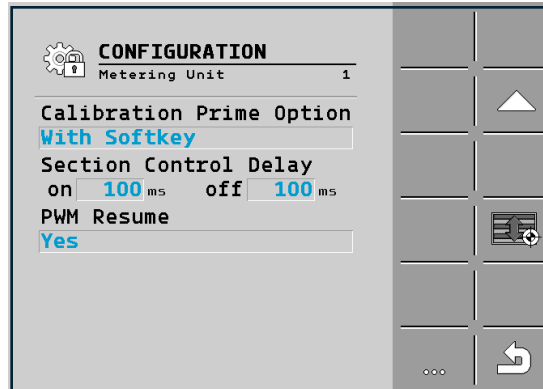

→ The Metering Unit Configuration 2 screen appears.

### **Section Control Delay**

This time is used by the UT terminal Task Controller to regulate or look ahead for starting/stopping sections with going into or out of overlap or entering/exiting a boundary of a field. Adjust the setting to increase or decrease this time. Typically, start and stop times should be the same.

### **PWM Resume**

PWM Resume is used for PWM controlled systems (Hydraulic Motor Actuator Type). This function is triggered from the implement switch. PWM Resume uses the last PWM % output and returns the system to that same value once back in work; Otherwise, the value resets to the min PWM value and ramps back up to the desired control level. Note that PWM resume does not retain this value with External or Master Switch cycling state.

Press the icon with three dots to cycle to the next Metering Unit

### **Slide Gate Sensor Calibration**

Press the Gate Sensor Calibration icon to begin.



→ The following window will appear:

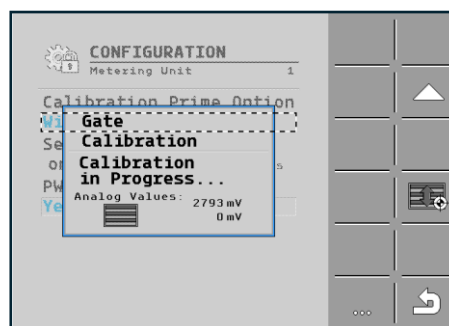

This calibration will move the gate from close position to the open position. This screen will show the sensor reading as the gate moves during the calibration cycle. Once both sensors read full stroke, the message will read calibration succeeded. Note that the hydraulics must be on and the fan running to move the actuators. This calibration is used only on slide gate cylinders with internal sensors. Slide gates with external white sensor boxes do not need calibration.

## Product Configuration

Product Configuration is where new products are added to the database, change the parameters of products, and set the target rate, Target Rate Increment, and Calibration Factor for each meter.

To access the Product Configuration from the Run Screen



→ The Product Configuration screen will be displayed.

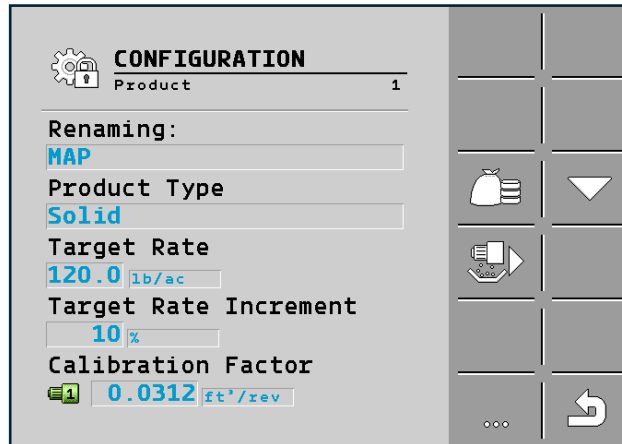

### **Renaming a Product**

To rename product, press the selectable area and type in the new name. Press the checkmark to save selection.

### **Product Type**

To change the product type, press the selectable area and choose one of the options: seed or solid. Press the checkmark to save selection.

### **Target Rate**

The Target Rate defines how much mass or volume of product should be applied per acre. The user can also change the target rate units to lb./ac, ksds/ac, oz/ac, or ton/ac based on the product type selected. To change the values, tap the selectable area, type or select the new value in the pop-up menu, and tap the checkmark to save the selection.

### **Target Rate Increment**

The Target Rate Increment is the percentage or unit of adjustment desired to bump the Target Rate on the Run Screen. To change the Target Rate Increment, tap the selectable area under this option. Type in the percentage or unit of change desired to be made with each button press. Tap the checkmark to save the selection. The units can also be changed to % or lb./ac.

### **Calibration Factor & Units**

Refer to the previous Calibration explanation in the Metering Drive Calibration section. The Calibration Factor will only need updated on this page when a new product is added to the database. (See “Adding a New Product” on the next page)

Refer to the Calibration Chart for calibration factors based on the machine type.

A number entered for one meter under the product database will update all meter values for that product to that value if it is a new product being added. If updating a current product, these values must be entered individually for each meter.

To change the calibration factor units, tap the selectable area next to the calibration value.

→ The following options will appear.

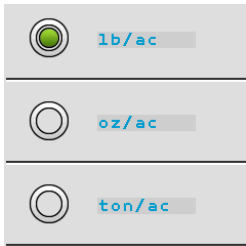

Press the Calibration Meter icon to cycle through the available meters.

Note the meter number changes on the meter icon.



Tap the down arrow to move to the next screen:

→ The Product Configuration 2 screen will be displayed.

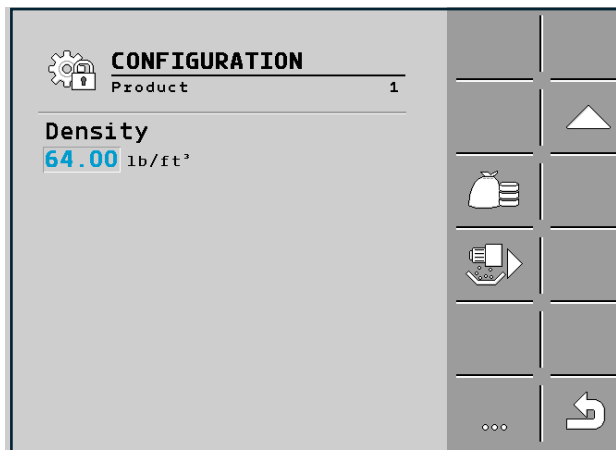

### **Density**

Enter the Density of the product using the density scale provided with the machine. Press the icon with three dots to proceed to the next product.



### **Adding a New Product**

To add a new product, tap the Product Database soft key. Tap the Product Addition softkey. Input the new product information. When adding a new product, the Calibration Factor can be entered once on Meter 1 and all meter Cal Factors in the Meter 1 Product Database will have the same value.



### **Removing a Product**

To remove a saved product, tap the Product Removal soft key. A pop-up window will ask if you would like to delete the product. Tap Yes to delete the product or no to return to the previous screen. Note that an active product in a hopper cannot be deleted.



## Profile Database Configuration

The machine type can be selected in the Profile Database Configuration. The operator needs a keyed code to enter this level.

To access this feature from the Run Screen



Pressing the down arrow under Machine Type brings up a list of selectable options. The operator can choose: Gen 1 - 1 Section, Gen 1 - 2 Sections, Gen 2, Gen 2 – 3 & 4 Products, and Fortifier.

The current machine type can be saved as a new profile by pressing the Save Configuration icon.

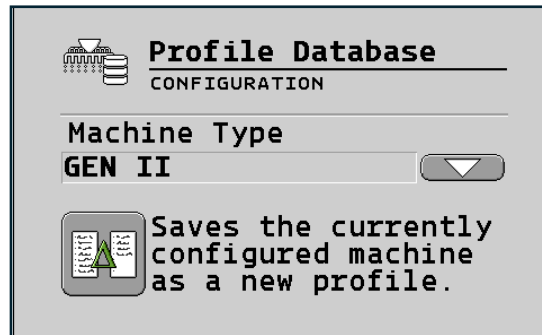

Press the **RED X** to delete the current profile and reset back to factory de- faults.

## Locked Area

Certain settings for the ISOBUS Control System reside behind a locked area. A security password is needed to enter this level. Contact your dealer for questions on how to access this area.



# Set-Up Guide

## 1 Implement Configuration

Page 31-34

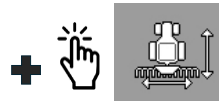
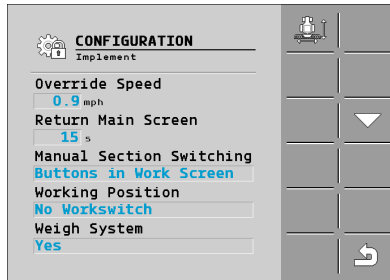

## 2 Product Configuration

Page 43-44

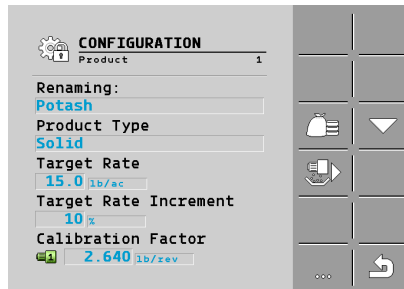

Calculate correct cal factor for machine. Use chart at the end of this manual for reference.

All meters must have values entered.

Use density scale to determine correct density

### 3 Shoot Configuration

Pages 36

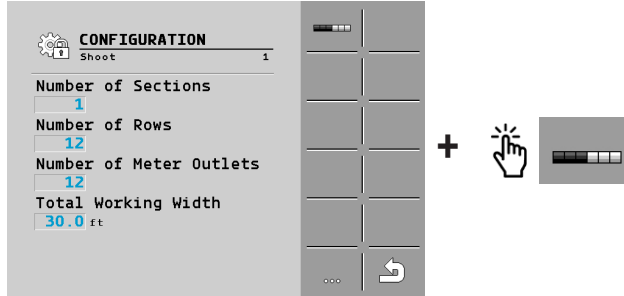

### 4 Slide Gate Sensor Calibration

Page 42

With hydraulics running...

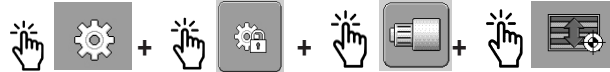

### 5 Fan Pressure Sensor Calibration

Pages 37-38

Follow the commands.

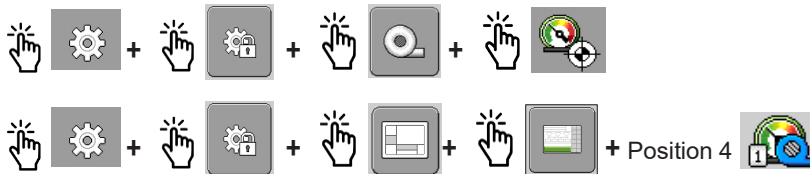

## 6 Fan Settings

Pages 27

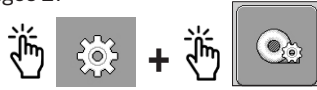

If using a Fortifier, set fan speed 4500-5500 RPM

## 7 Speed Settings

Pages 27-29

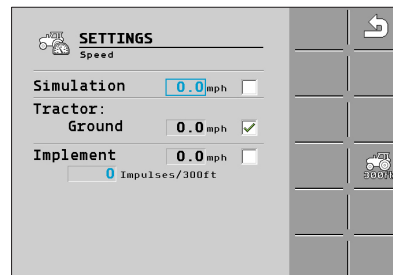

It is recommended to run meters in simulation speed with **no product** in the tank to check correct set-up of sections and settings. Using Montag App for correct outputs.

## 8 Hopper Info Screen Page 13

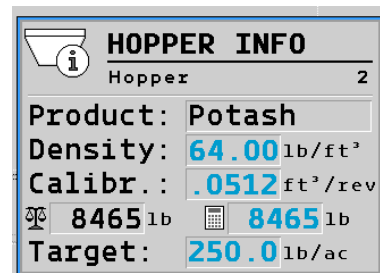

Values in **blue** can be edited from this screen.  
Scale weights from load cells and calculated weights can be compared

# 9 Hopper Settings

Page 11, 18

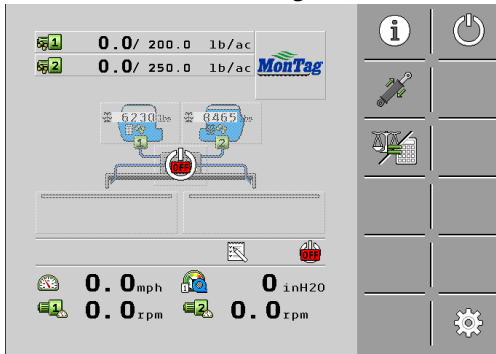

Equalizes calculated weight to scale weight. It is recommended to equalize the tanks after **every** fill.

# 10 Additional Set-Up Features

## Road Mode Feature

Page 15

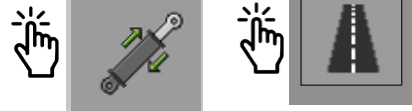

## Slide Gate Feature

Page 17, 58

	Gate Open - Tap the icon to open the gate incrementally. Press and hold the icon to open the gate completely.
	Gate Close - Tap the icon to close the gate incrementally. Press and hold the icon to close the gate completely.

## Using Prescription Rate Control

Page 12, 53



## Using Bin Chaining

Page 17-18

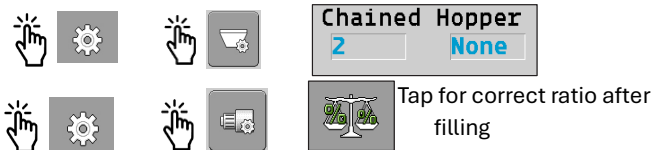

# Operating the Implement in the Field

## Start Applying

- The implement is moving and shows ground speed on home page.
- The implement is lowered work switch is activated if used.
- The metering cells are filled with product.
- The fan has reached the minimum revolution speed.
- Rate, cal factor, density, and machine settings are entered correctly.

1. Start applying. Press the Sections Master icon.



## Filling Auger with Product

To be able to apply product from the beginning and avoid blank spots at the start of the field, fill the metering augers prior to driving by using the pre-metering function.

1. On the Run Screen, press Metering Cell icon.



→ As long as the metering cells are being filled, the following icon appears in the Status Line of the Run Screen:



2. Allow time for the product to reach drop point before driving

## Stop Applying

1. Stop applying. Press the Sections Master icon.



→ All of the metering drives are stopped.

## Adjusting the Target Rate during Operation

The Target Rate can be adjusted while working. This can be done for both hoppers together or independently. Use the icons on the right side of the display to increase, decrease or return to the Target Rate.

Function Icon	Meaning
	Increases the Target Rate of a specific hopper. The target rate is increased by the percentage defined in Product Configuration.
	Reduces the Target Rate of a specific hopper. The target rate is reduced by the percentage defined in Product Configuration.
	Restores the target rate of a specific hopper back to 100%.
	This icon shows the delta target rate for the hoppers. Pressing this icon brings up the icons below on the right side of the screen.
	Increases the Target Rate for both hoppers. The target rate is reduced by the percentage defined in Product Configuration.
	Reduces the Target Rate for both hoppers. The target rate is reduced by the percentage defined in Product Configuration.
	Restores the target rate back to 100%.

The Target Rate and Delta Target rate are defined in Product Configuration.

### Changing the Target Rate of an Individual Hopper

1. On the Run Screen, press a Metering Drive:



→ Function icons for the adjustment of the Target Rate appear on the right.

2. Press the increase or decrease icon from the right side of the display to change the Target Rate (note product 1).



→ The target rate of the metering units will be changed:

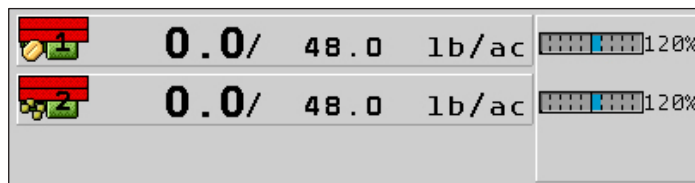

→ The ECU regulates the application according to the new Target Rate.

## Changing the Target Rate for both Hoppers

1. On the Run Screen, press Delta Target Rate or Montag icon:

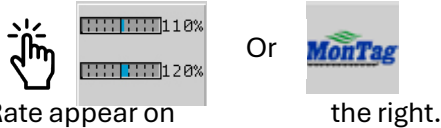

→ Function icons for the adjustment of the Target Rate appear on

2. Press the increase or decrease icon from the right side of the display to change the Target Rate.



→ The target rate of both the metering units will be changed:

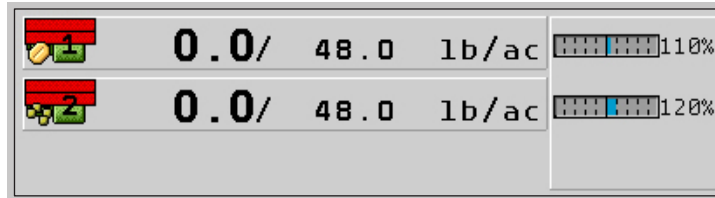

→ The ECU regulates the application according to the new Target Rate.

## Operating the Hydraulic System with the ECU

The ECU is used to adjust the position of the hydraulic valves through a PWM control voltage. The percentage of PWM controls the speed of the auger motors of each product. The ECU calculates the PWM signal based on target rate, ground speed, density and calibration number.

When operating the Dry Rate Controller with the ECU, remember that it cannot control the oil pressure. Use the SCV control in the tractor to generate pressure in the system. Adjust the hydraulics by setting the fan pressure between 10-25. The machine type and rates, product density, and rows determine fan pressure needed. Gen 1 and Fortifiers require the highest pressures, with 2108 machines using the least. Refer to operator's manual for each specific machine. Run at the lowest rate without causing blockage. It is best to start higher and decrease hydraulics to the optimal setting for the machine and application. Running too high will cause premature hose failure and use more horsepower. Most Gen 2 machines will run 15-20 inches of H<sub>2</sub>O. Too low fan pressure will not allow product to reach the end of hose and discharge into the ground. As product backs up in the hose's blockages will occur and eventually stop the meters.

For 2 or more sections, turn on 1 section at a time to make sure product is coming out the correct section.

**Montag Toolbox** is used on Android and Apple devices and is available to all customers at the Play Store or App Store. User enters machine type, rate, ground speed, density, number of rows and row spacing. The app will show theoretical auger speed which can be compared to the Montag machine at set-up to verify all the parameters have been entered correctly.

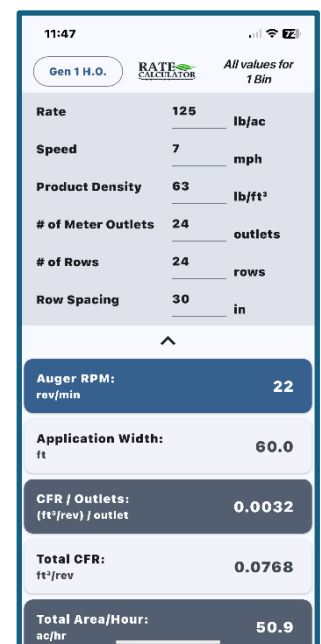

## Operating Section Control

With section control, independent sections of the implement can be turned on and off. The size of the respective sections switched depends on the implement type and equipment.

The Run Screen shows which sections are switched on or off.

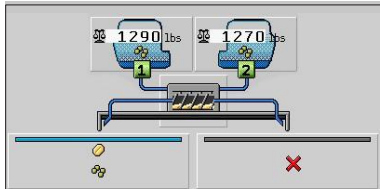

Left section is on and right section is off.

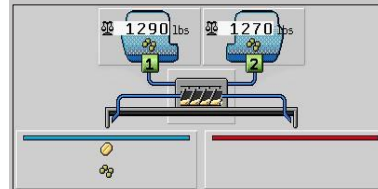

Right section has been turned off by the Task Controller.

When product is coming out of the section, there is a granular icon in the window. The color of the section indicates its status: **BLUE** = sections on, **GREY** = sections manually off, **RED** = sections turned off by section control.





### Auto/Manual Section Control Softkey



This softkey will appear on the right side of the screen when Task Controller is running with Section Control Enabled. This button allows manual control of the sections. If Task Control tells the sections to turn OFF, this will override Task Control to turn the sections ON.

## Using Prescriptions

Prescriptions allow the Task Controller to vary the application rate while the system is in operation. Consult the OEM display manual for instructions on how to load prescriptions for each specific display. Once a prescription is loaded into the display, follow these steps to assign it to the Dry Rate Controller System:

1. From the Run Screen, press the Delta Target Rate icon.  
2. Press the Prescription icon from the right-side menu. This icon will only appear if the display has a prescription loaded.  
3. When the system is using a prescription, the meter icon will change. 

## Viewing and Clearing Counters Page

The counters page is used to store trip values, amount applied, area, time, and distance. These values are allowed to be cleared whenever the operator needs them to be cleared.

It also stores total tonnage, area, working time, distance and powered on time. These values are stored in the ECU and can only be cleared by a service tech.

1. Select the trip values function button on the main page. A list of the products and empty blanks will be displayed.



→The Results screen will display the current products in the hopper. To see other products, they first must be entered on hopper settings page as associated products.



2. To clear the trip results, press the corresponding hopper trip clear function icon.

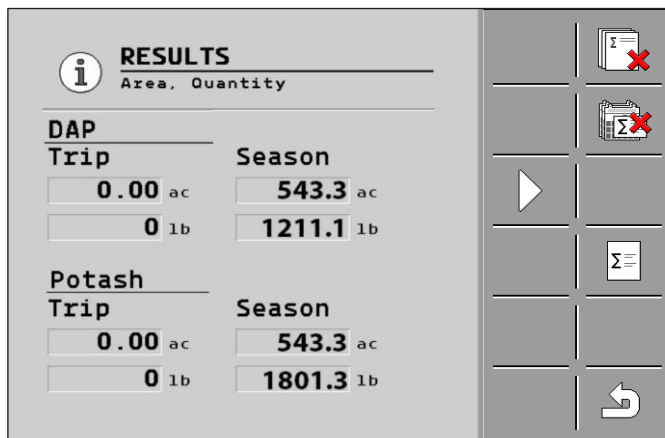

3. To clear the season results, press the corresponding hopper season clear function icon.

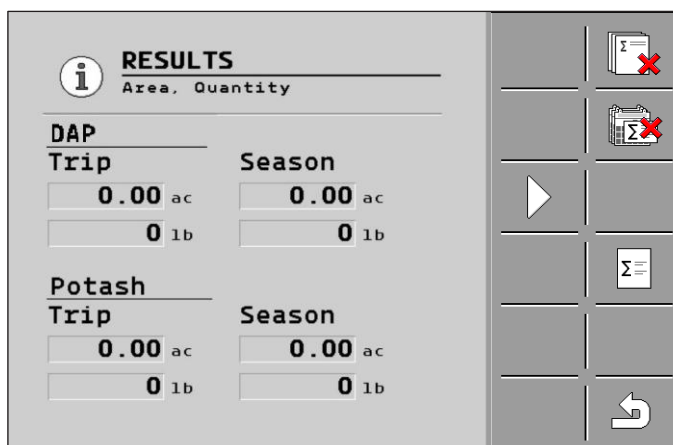

4. To view the total values, press the total function icon The Total Counter Page will be shown.

→ The Results screen will be displayed.

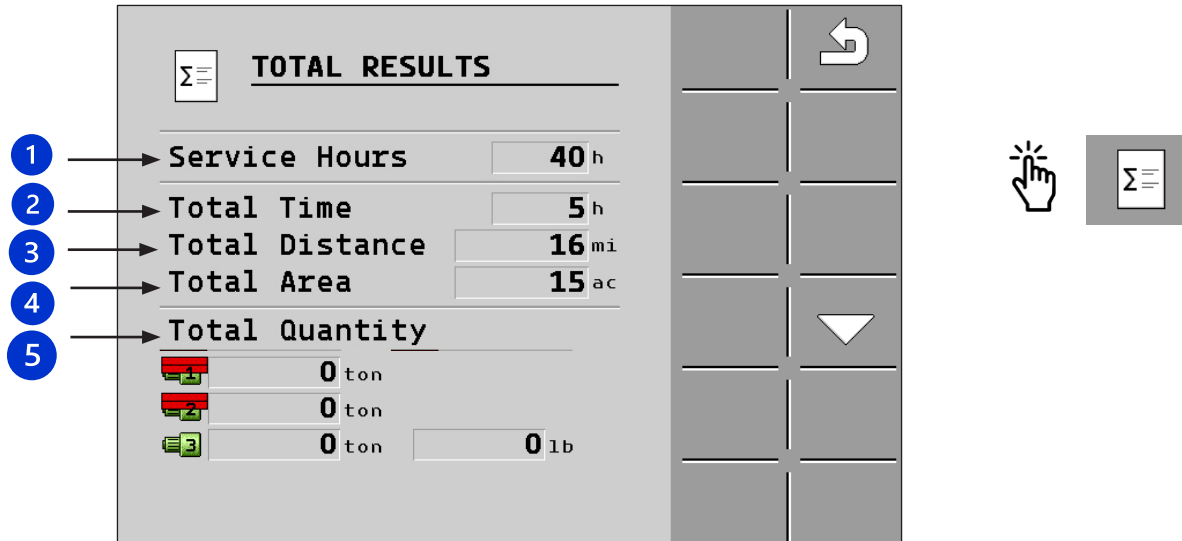

1	Service Hours Total time has powered up since ECU was powered up.
2	Total Time Total time during work since ECU was powered up.
3	Total Distance Total distance traveled during work since ECU was powered up.
4	Total Area Total area covered during work since ECU was powered up.
5	Total Quantity The total weight of each hopper since ECU was powered up.

Press the down arrow to view the Total Quantities for additional meters (when applicable).

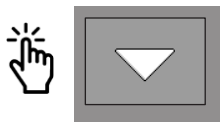

# Troubleshooting

## Performing Diagnostics

The Diagnostics screen shows the measured values for all the sensors on the machine. In addition, testing can be performed by turning outputs on and off showing whether the functions of the ECU are working as desired.

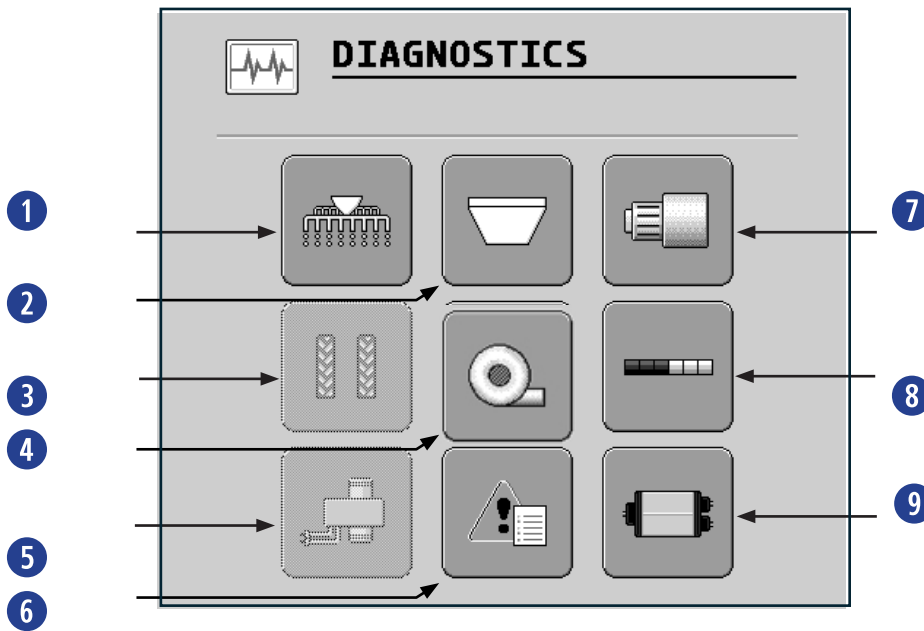

1	Implement Diagnostics	6	Alarms
2	Hopper Diagnostics	7	Metering Diagnostics
3	<i>not used</i>	8	Section Diagnostics
4	Fan Diagnostics	9	ECU Diagnostics
5	<i>not used</i>		

### **Implement Diagnostics**

The Implement Diagnostics show feedback for Radar Impulses, Working Position, and the Case Drain Hydraulic Switch.

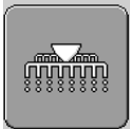

**DIAGNOSTICS**  
Implement

Hydraulic Pressure  OFF

### **Hopper Diagnostics**

The Hopper Diagnostics show feedback on hopper weight and hopper product.



**DIAGNOSTICS**  
Hopper

12115 lbs 3515 lbs

Calculated Content  
12115 lb 3515 lb

Content by Scale  
12115 lb 3515 lb

... ↻

Press the three dots softkey to cycle to hopper diagnostics for any additional hoppers (*When applicable*).

### **Fan Diagnostics**

The Fan Diagnostics show feedback on fan pulses if using a proximity sensor and fan RPM. Pressure Sensor feedback will only be shown if a pressure sensor is enabled and calibrated. The sensor will read between 3.9-4 mA when the fan is not running. The upper end depends on the fan pressure set by the SCV.



**DIAGNOSTICS**  
Fan

1 5831 4435 rpm  
7.54 mA 16 inH2O

## Metering Diagnostics

The Metering Diagnostics show PWM feedback. If applying, entering this screen will show PWM output per percentage, the number of pulses and RPM of the meters. Pressing the plus or minus buttons manually controls meter speed. A manual PWM percentage can be entered at the selectable area. If either of these diagnostic tools are used, the drives will turn regardless of Master Switch state, fan speed, ground speed, or working position. Only start when all safety procedures have been observed.

Leaving this screen will either return to controlling to rate if the Master Switch is on and applying, or the drives will shut off if the machine is not applying (due to master off, working position out of work, zero speed....).

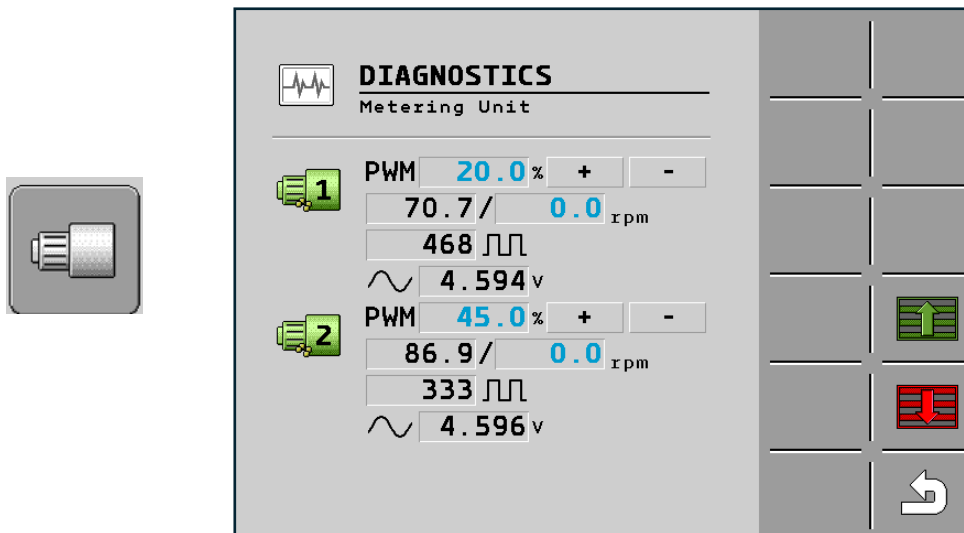

Press the icon with three dots to view additional meter feedback.



## Section Diagnostics

The Section Diagnostics show the output pin numbers for each section.

- Select the section to diagnose.
- This page identifies which section is selected and the ECU pin.
- Output 0=ON 0v or 1=OFF 12v
- Press the checkmark and X icons to turn sections on and/or off.
- **WARNING:** If sections are turned off on this screen, they do not reset when returning to the Run Screen. The sections must be turned back on before exiting section diagnostics.

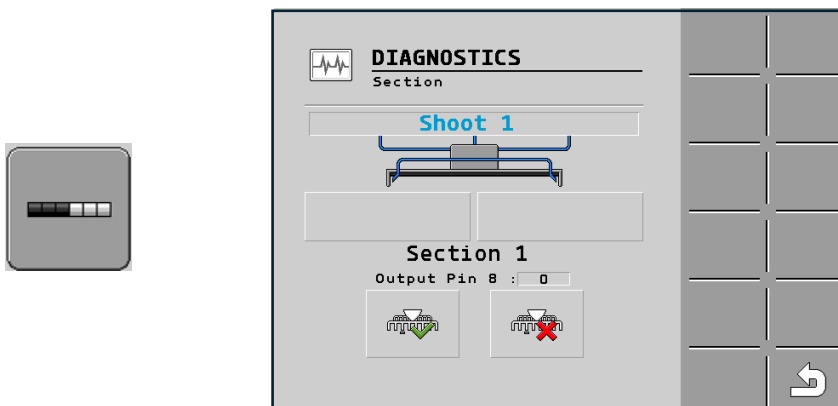

## ECU Diagnostics

The ECU Diagnostics shows:

- Software Version
- Object Pool Version
- Power Voltage and Sensor Voltage
- ISOBUS CANload and SubBus CANload



**DIAGNOSTICS**  
ECU

MonTag Mfg  
Software : v02.02.09.01  
Pool : v1.00  
Build Date: 2024-04-23  
Power Voltage: 11.769V  
Sensor Voltage: 11.747V  
ISOBUS Termination: ON  
ISOBUS CANload: 1%  
SubBus CANload: 0%

## Alarms

The Alarm Concepts Diagnostics show warnings and alarms that the system has issued for the current power cycle (*This list is cleared upon powering down the ECU*). The green checkmark or red circle on the right side of each button shows whether the alarm was accepted or rejected by the user when issued.



**ALARMS AND WARNINGS**

07/01/001 Implement 1 ✓

Tapping on each warning button will bring up the details of the alarm.



07/01/001 Implement 1 ✓

If the alarm was originally accepted when issued, a red circle softkey will appear on the right side of the screen.

**ALARM**  
Implement 1

Pressure Sensor  
outside  
operating range!

Alarm 07/01/001

Tap this soft key to ignore the alarm.

→ The following screen will appear.

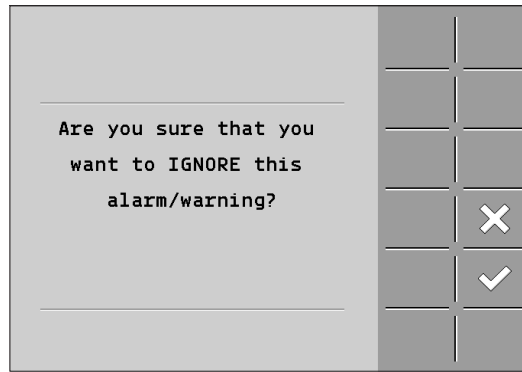

To confirm ignoring the alarm, press the checkmark soft key. To decline ignoring the alarm, press the X soft key to return to the previous screen.

If the alarm was originally ignored when issued, a white circle soft key will appear on the right side of the screen.

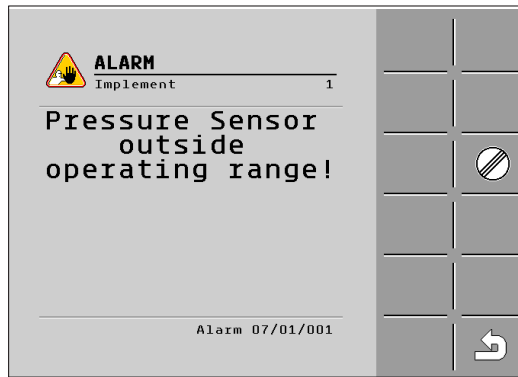

Tapping this soft key will accept the alarm and return to the main Alarm screen. Accepting a previously ignored alarm will also remove the Alarm Icon from the Status Line of the Run Screen. (Configure the Alarm Concepts Status Line Icon in the Status Line Configuration.

## Case Drain Alarm

The Case Drain Alarm is a safety warning that case drain pressure has reached a dangerous level. High pressures can damage fan shaft seal. When this alarm is on all product applications are stopped until the issue is corrected. The operator should check the case drain connection at the tractor.

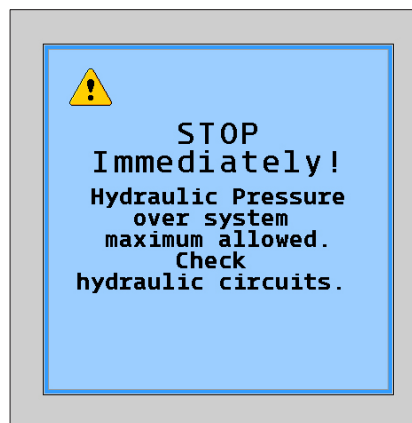

# Troubleshooting Guide

Symptom	Problem	Solution
Scale drops off/doesn't show up	Scale VT does not show up on homepage	<p>Check Scale ISO connection, the 6 or 8 pin Deutsch connector connected to scale ECU for corrosion/damage/bad connection.</p> <p>Remove cover (4 screws) on the Digistar SL2140 ISO. On the right side there should be 4 blue LED on, and the 3 status LED on the left side should be off.</p> <p>On Scale Tec Point system verify most current software is loaded.</p> <p>Check system voltage, on Montag screen, under diagnostic button, under ECU, voltage should be 12.2V or greater.</p> <p>Check ISO Connector under Fortifier for corrosion/connection.</p> <p>Restart Hagie/tractor/Display.</p> <p>Verify all ISO connections are correct.</p> <p>If using a monitor that requires a USB key for data, try a different USB key, or try removing it.</p>
Digistar/Point VT good, not on Montag homepage	Scales not set up	Verify scale system setting is set to "Yes" on Montag VT.
Scales showing erratic readings	Possible bad Scale Link ISO node, j-box, or load cell	<p>Verify correct Digistar Cal # for both tanks are set up 115030 and Cal 5333.</p> <p>Use GT 400 interactive troubleshooting guide and watch trouble shooting video under controller info tab on Montag website for troubleshooting diagnostics.</p> <p>If testing loadcell by tap test, if bad it will jump 1-2 thousand.</p> <p>Look for areas of hang-up or binding.</p>
Calculated weight and actual weight off	Set-up incorrect	<p>In hopper screen, equalize weights and recheck.</p> <p>Check if cal factor is correct, check density of the product with Density scale.</p> <p>Check # of rows and total implement width. Configure as a new product and retry.</p> <p>Example set-up 30 lb./ac, 10 mph, 45lb/ft<sup>3</sup>, 12 row, 120' total width, Cal factor .036, the auger speed should be 45 ± 1 RPM auger speed. Use Montag App for your specific machine.</p> <p>Count auger RPM as machine is running and compare to the RPM on the screen. If off then check set-up parameters.</p>
	Calibration factor off	<p>Do calibration test- either catch or no-catch test.</p> <p>No catch test calibration must start with fan on and end with fan on. Also start and stop test on level ground for scale accuracy.</p> <p>Verify no sheared couplers.</p> <p>Verify hydraulic motor drive shaft couplers are properly connected and augers are turning</p> <p>Calculated correct auger output speed using Montag App</p>

Montag screen drops off/doesn't show up	Montag VT does not show up on home page	<p>Check ISO Connector at tractor for corrosion/connection. Restart tractor, let screen power up for 20 sec before starting tractor. Check all ISO and power connectors under machine for corrosion/connection. Verify all ISO connections are correct. Restart machine/Display.</p> <p>If using a monitor that requires a USB key for data, try a different USB key, or try removing it.</p> <p>Make VT1 post monitor and VT2 Armrest (Deere only)</p> <p>Check Digistar ISO connection, the 6 pin Deutsch connector (18" whip out of the bottom of the SL2140 ISO control box) for corrosion/damage/bad connection.</p> <p>Remove liquid ECU from BUS. Remove other ECUs on bus one at a time.</p> <p>Make sure terminator are in correct location, one at the front of the bus and one at the end.</p>
Controller not working	Erratic and inconsistent results from controller	<p>Delete object pool on monitor.</p> <p>Check system voltage, on Montag screen, under diagnostic button, under ECU, voltage should be 12.2V or greater.</p>
Slide gate will not open	Slide gate will not function	<p>Make sure hydraulic couplers are properly connected and fan is on.</p> <p>If in road mode, push road mode button to get to application mode</p> <p>Check slide gates from diagnostics screen.</p> <p>Verify solenoid and position sensor harness connections are good and harness is in good condition.</p> <p>Slide gates not calibrated or incorrect calibration. See calibration instructions in Controller Operation Manual.</p>
	Slide gates open/close opposite controller	Harness connections at coil are swapped. Switch red and green harness at coil on hydraulic block on Montag.
No Product being delivered -All rows	Fan not turning	<p>Verify all three hydraulic couplers are fully engaged with machine off and key removed, see if fan rotates by hand. If fan is not binding on housing, and does not rotate by hand, replace fan motor.</p> <p>Fan not calibrated or out of calibration. Calibrate per instructions in ISO Dry Rate Controller Operation Manual.</p>
	Fan air gauge pressure less than 12-inch H2O	<p>Fan rotation must be clockwise (CW) when viewed from the screen side of fan. If rotation is not CW, see Hydraulic Schematics in Montag manual and plumb as shown for the machine.</p> <p>If analog gauge reads correct, but digital transducer reads incorrect, calibrate air sensor following instructions in manual.</p> <p>Set gap between fan and pick-up bolts to 1/4 inch (6MM). Check gap between fan impeller and end of housing (.0625-.156").</p> <p>Check for any air leaks in plenum tray or air chambers or anywhere in system.</p>

	Augers turn wrong direction	Augers must turn CCW. Check hydraulic schematic and verify each hydraulic motor is in correct position. Check all augers and clean out system. Close slide gate and run meters in diagnostics mode. Check all augers for rotation and replace any sheared couplers. Clean out hoses and make sure air is coming out each hose at boom before starting to apply product.
	Auger(s) not turning	Confirm the fan is running. Augers will only turn while fan is running. Confirm augers are not obstructed. Safely remove any obstructions by following clean-out instructions in Montag machine manual. Check controller set-up is complete with correct product info (density, cal factor, rate, ground speed is registering. If using prescriptions, verify mapping is in correct format and entered correctly. Verify prescription icon is by rate on home screen, and a non-zero target rate is on display side. Verify sections are on and if using section control, be sure not located in an already applied area. Try running with section control shut off and without prescription, just a flat rate.
	Master switch not set up correctly	Follow instructions in controller manual for correct master switch set-up. When master is toggled on/off the master icon on the meter will switch to augers, section boxes will become lit, and boom section lights will switch on.
	Problem with encoder or PWM valve	Shut slide gate and run meters in diagnostic screen. If it still does not run, set meters to 100% and check for 12 VDC at PWM valve. Look for harness damage. If augers turn but no RPM, check encoder harness for given tank. Test for 12 VDC on pins 1 & 3 of encoder harness. Remove plastic cap over encoder motor shaft to verify hydraulic flow at encoder motor. If 12VDC at harness and motor turning replace/ adjust sensor in motor. Follow replacement instructions so as not to void any current warranty.
	Controller not seeing speed	Check that controller is seeing speed and correct speed when machine is moving. Verify GPS and display are properly set-up and functioning.
No Fertilizer in 1 or more rows	Coupler(s) sheared/hoses plugged	Check all augers and clean out system. Close slide gate and run meters in diagnostics mode. Check all augers for rotation and replace any sheared couplers. Clean out hoses and make sure air comes out at each hose at toolbar/boom before starting to apply fertilizer. See instructions for calculated and actual weight off. If using bin chaining, verify set up correctly as directed in controller operation manual. Combined auger speeds should be less than 130 RPM(Fortifier).

	Product Bridging	With fan still running look at auger cartridge for bridging or obstruction which does not allow product to flow evenly. Shut off fan and then back on to see if issue persists. Open/close slide gate to break up bridge. Air pressure may be too high Product is too moist or has too many fines
Not holding rate	Alarm "Metering drive cannot maintain target rate"	Check for correct product info (density, cal factor, rate). Augers RPM should be between 5- 105 range for Gen 2. 5-120 for Gen 1 machines. Verify correct ground speed. Adjust meter amplification factor. Add a new product with correct numbers. Clear object pool by following monitor manufacturer's instructions. Power cycle controller/display. Verify correct cal factor for that product for that meter. May need to increase ground speed if running to low of an auger speed (under 10 RPM).
One tank not holding rate	Set-up incorrect Bad speed sensor cable	Check for correct product info (density, cal factor, rate). Shut slide gate and run meters in diagnostic, verify shaft RPMs for both tanks. Check all harnesses and harness connections to motor encoders and PWM valves. Power cycle controller/display.
Section Control not working	Sections turn off, but will not go back on	If running an Ag Leader, verify target rate entered on both Ag Leader and Montag. If section box gray with red X, then touch button again to shut off manual section button. If section box is red with red X, then map or controller is turning section off. If in an already applied area, section will be red. Move to an area not applied yet or shut off section control on display. If a prescription is loaded, move within map area. Verify look ahead and implement geometry settings are correct.
	Section bars are visible, but not able to turn on and off. No box around them.	May need to update configuration or software. Contact your dealer for assistance.
Product not coming out in correct section	Product hoses not in correct location	Check Montag's website for correct hose layout and row configuration charts. Adjust hoses as necessary.
	Harness on incorrect PWM valve or section motor	Swap harness location for 2 section machines.
Mapping not working	Layers not set-up correctly	Contact monitor dealer for set-up instruction for 2 product application.
Rate is not correct	Using bin chaining	Follow instructions in controller operations manual. Total auger RPM must be under 130 RPM to prevent plugging.

# Updating Firmware on ECU controller

Instruction Guide for update software. Current software is available from your Montag dealer.

It will be necessary to set up fan pressure sensor calibration after update. The hydraulics will need to be functional and a magnehelic gauge reading 0-30 inches of water is needed to correctly calibrate fan pressure.

If a gauge is not available, it is possible to run the machine and get current air pressure before downloading and use that pressure for the calibration number (given the hydraulics are not adjusted and the sensor was calibrated correctly and is currently functioning properly). The preferred and correct procedure is to use a gauge for each calibration.



Delete the object pool on monitor or run disk clean-up on your monitor.

Start by taking screenshots of pertinent information on configuration pages that may be lost during download (products, calibration #s, geometry, work switch option, any other set-up parameters). Depending on what versions, more or less will have to be re-entered. Also capture info page screens as this info may be lost.

[Montagmfg.com](http://Montagmfg.com) has current Dry Rate Controller Operations Manual, Set-up Guide, Quick Reference Guide, and video tutorials with detailed instructions.

Files from dealer to download should be installed on USB key in folder named "Download"

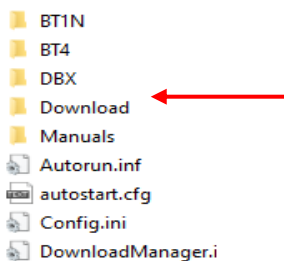

Power down the tractor, install harness, download box, and USB key. Power up, the LEDs on the download box should be green. This page is the correct page that comes up. select the folder button.

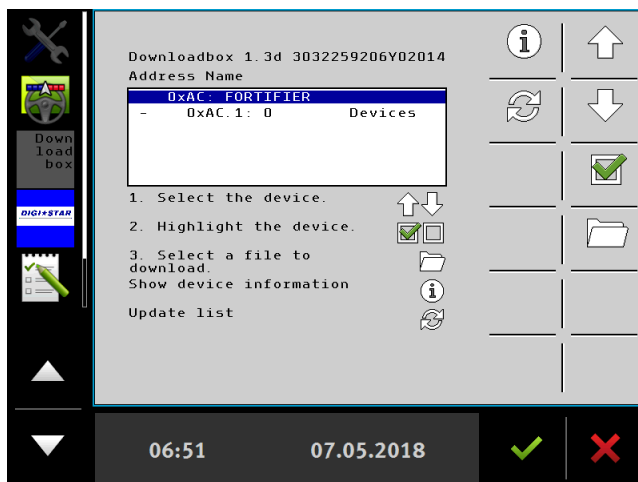

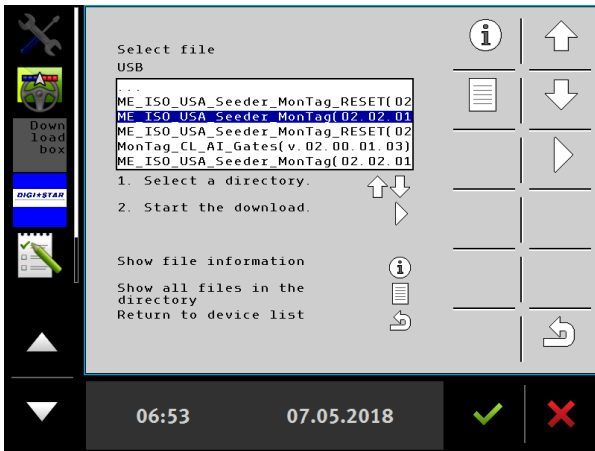

Select the correct file to download using the up and down arrows. The i (info) button will show the complete title name and more of the selected file.

Once the correct file is selected (in blue) press the enter (triangle) button.

This slide shows the complete file name under info button. in this example, 02.02.01.10 is the version being Downloaded.

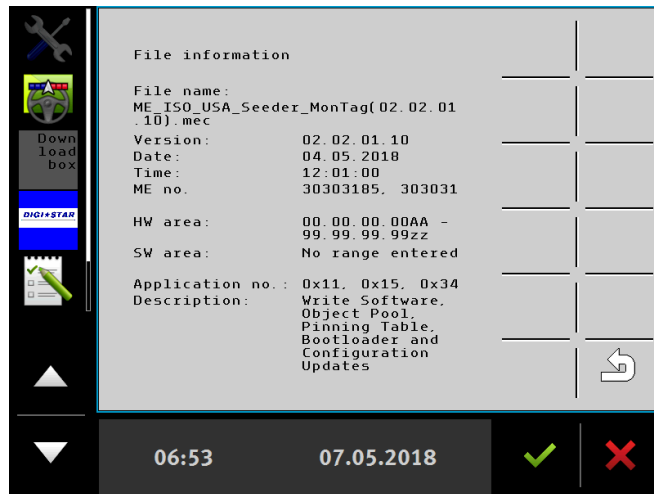

The status bar will show progress of download.

Depending on the file, this could take up to 10 minutes.

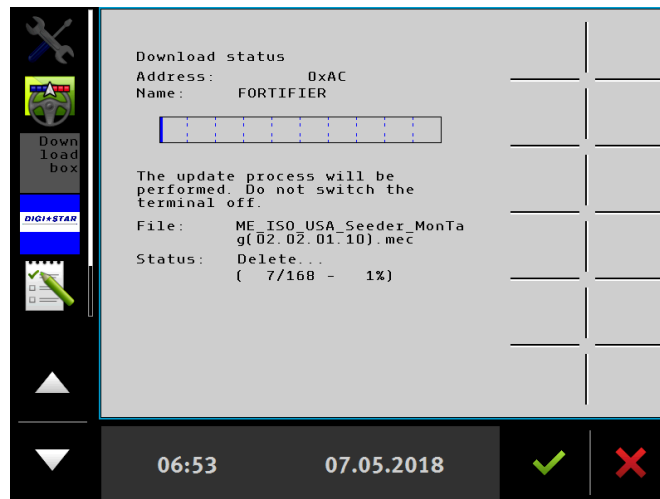

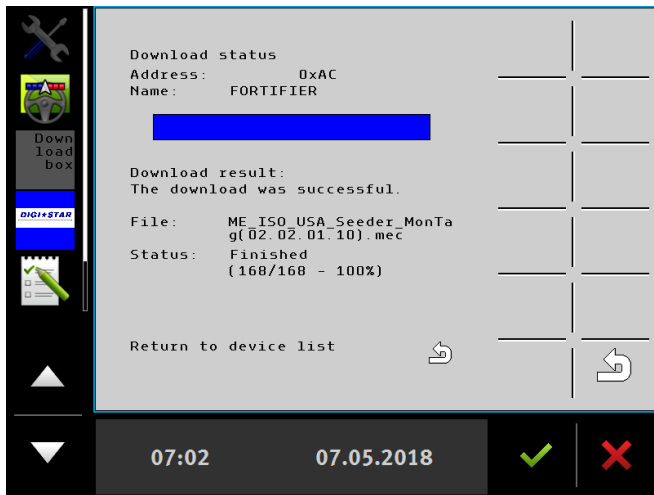

When complete, the result will show download was successful and will show 100%.

Hit the back arrow and repeat with all files instructed to download.

Always run the .mec file first. It may be necessary to run the rest file if uploading from a version older than V.02.02.01.00 or if running a beta version.

After running the .mec file/reset file, power down and remove download harness/box and connect ISO plug to tractor. After re-powering, this screen will show. Select the correct machine type from the section box. When selected, accept with the green check. Let the machine re-boot and then re-enter data for set-up.

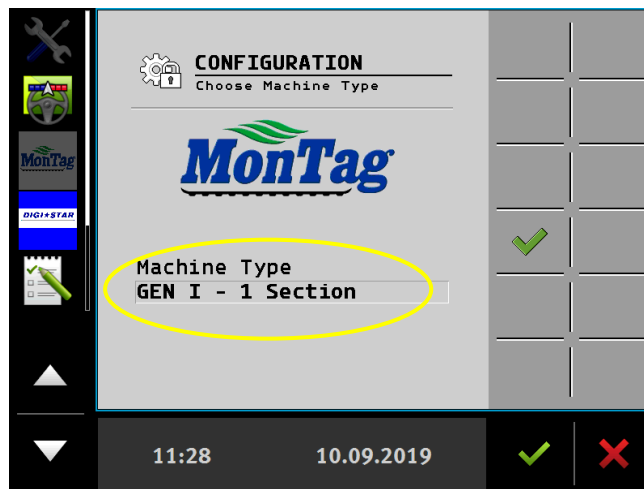

## For Gen I machines only

Metering Unit Resolution requires 2 different pulse counts, depending on the motor installed

Parker is 30 pulses/rev

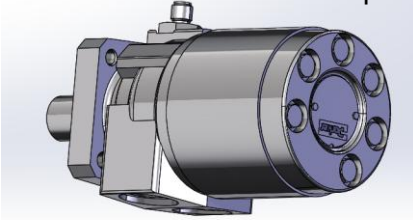

Sensor parallel with hose connections  
End cap bolts flush with end of motor

Eaton is 60 pulses/rev



Sensor 45 deg off hose connections  
End cap bolts protrude from end of motor

Current software uses Parker 30 pulse as default in software. If installing software on a machine that uses An Eaton hydraulic motor, the following setting adjustment must be done at time of software update.

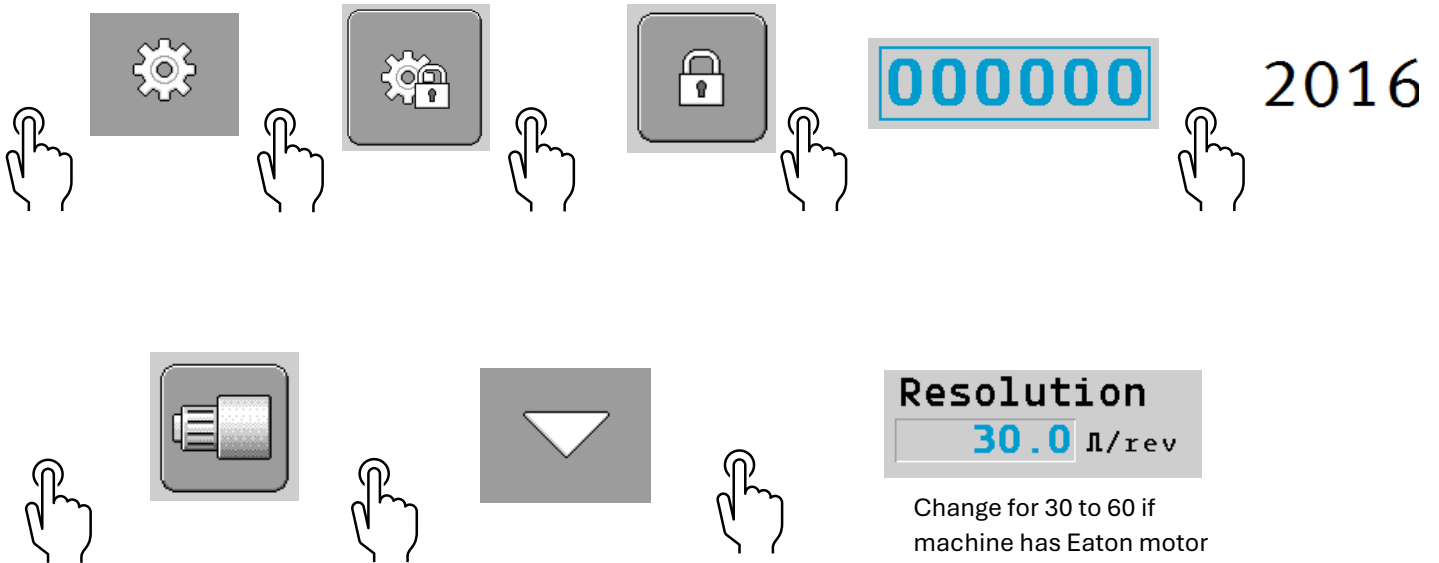

## For Gen II machines only

Slide Gate type has two options, depending on MY of machine. Default setting for current software updates is Analog Slide Gate.

**If updating an older machine to newer software, it is necessary to change value to digital slide gate.** Follow the procedure below

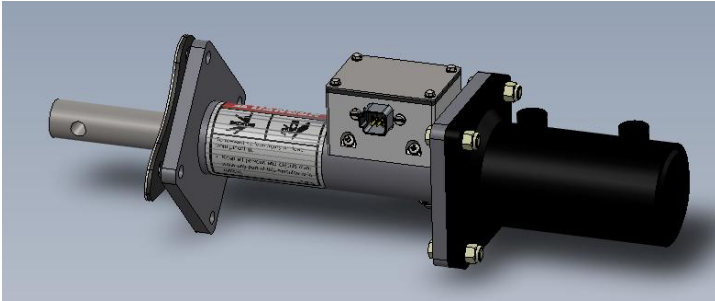

Digital Slide Gate

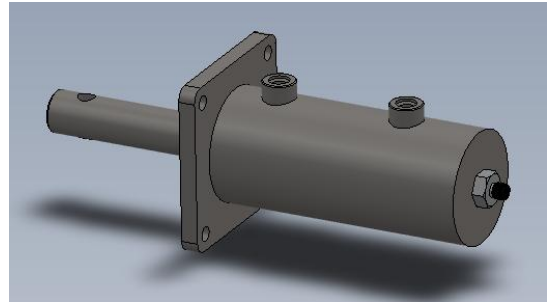

Analog Slide Gate

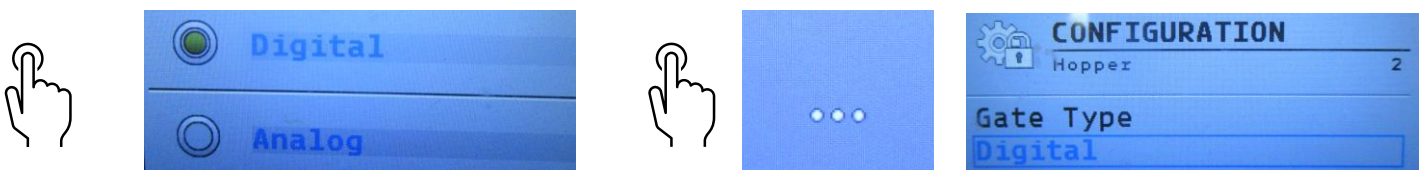
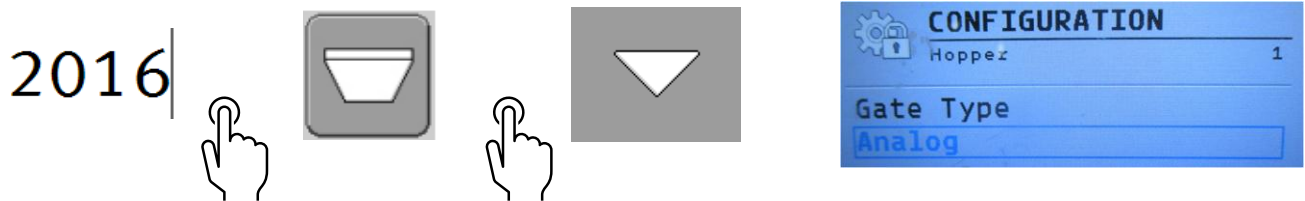
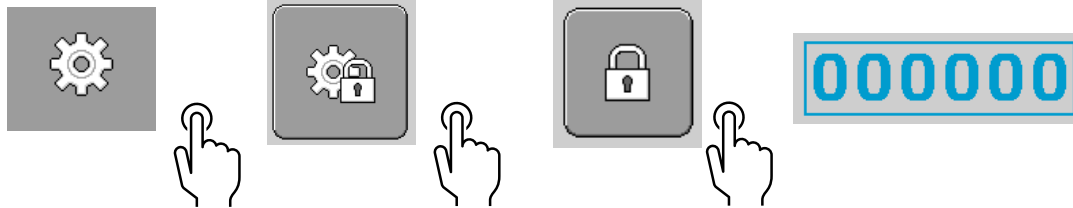

Must change for both hopper 1 & 2

# Technical Data

## Gen 2 Harness Diagram

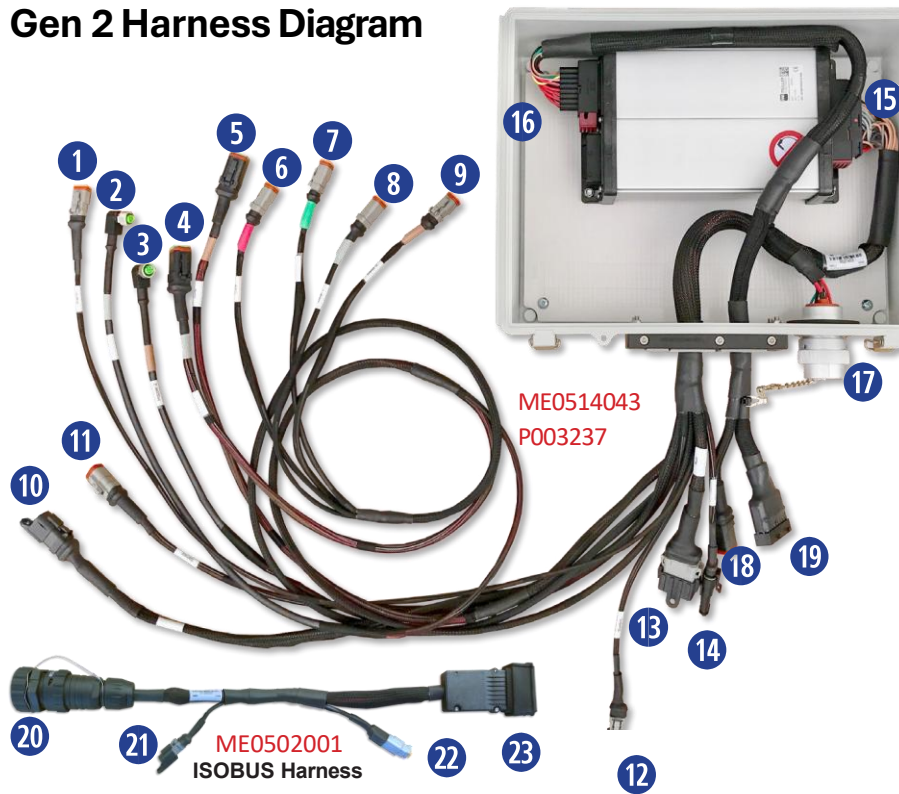

## Gen 2 Cable Pin Diagrams

**1**

Hydraulic Alarm - X8		
Cavity	Description	Wire Color
1	Case Drain	Tan
2	0v Electronic	Black/White

**2**

Encoder Hopper 1 - X6 M12		
Cavity	Description	Wire Color
1	12v Electronic	Red/White
3	0v Electronic	Black/White
4	Meter 1 Encoder	Tan

**3**

Encoder Hopper 2 - X7 M12		
Cavity	Description	Wire Color
1	12v Electronic	Red/White
3	0v Electronic	Black/White
4	Meter 2 Encoder	Tan

**4**

Bin 1 Gate - X12 M12		
Cavity	Description	Wire Color
1	12 VDC	Brown
2	Signal	White
3	0 VDC	Blue
4		

**5**

Bin 2 Gate - X13 M12		
Cavity	Description	Wire Color
1	12 VDC	Brown
2	Signal	White
3	0 VDC	Blue
4		

6

Close Gate - X15		
Cavity	Description	Wire Color
1	Close Gate HS	Grey
2	0v High Current	Black

7

Open Gate - X16		
Cavity	Description	Wire Color
1	Open Gate HS	Grey
2	0v High Current	Black

8

PWM Meter 1 - X2		
Cavity	Description	Wire Color
1	PWM Meter 1	Grey
2	0v High Current	Black

9

PWM Meter 2 - X3		
Cavity	Description	Wire Color
1	PWM Meter 2	Grey
2	0v High Current	Black

10

Sections - X5		
Cavity	Description	Wire Color
1	0v High Current	Black
2	Section W	Grey
3	Section X	Grey
4	Section Y	Grey
5	Section Z	Grey
6	0v HC	Black

11

Fan Pressure Sensor - X17		
Cavity	Description	Wire Color
A	12v Electronic	Red/White
B	Fan Pressure Sensor	Tan
C	0v Electronic	Black/White

12

Implement Switch - X10		
Cavity	Description	Wire Color
1	Work Position	Tan
2	0v Electronic	Black/White

13

Aux - 18		
Cavity	Description	Wire Color
1	12v High Current	Red
2	Encoder 3	Tan
3	Encoder 4	Tan
4	12v Electronic	Red/White
5	0v Electronic	Black/White
6	Fan 1 Encoder	Tan
7	Fan 2 Pressure	Tan
8	Aux Input 2	Tan
9	Fan 1 PWM	Grey
10	PWM 4	Grey
11	PWM 3	Grey
12	0v High Current	Black

14

Ground Speed - X11		
Cavity	Description	Wire Color
1	0v Electronic	Black/White
3	12v Electronic	Red/White
4	Machine Speed Signal	Tan

15

Main - X1		
Cavity	Description	Wire Color
1	12v High Current	Red
2	Encoder 3	Tan
3	Encoder 4	Tan
4		
5		
6		
7	Section W	Grey
8	Section X	Grey
9	Section Y	Grey
10	Section Z	Grey
11		
12		
13		
14		
15	PWM 4	Grey
16	Work Position	Tan
17	Case Drain	Tan
18	Fan 2 Pressure	Grey
19	Fan 1 PWM	Grey
20		
21	PWM Meter 1	Grey
22	PWM Meter 2	Grey
23	PWM Meter 3	Grey
24		
25	Open Gate HS	Grey
26	Close Gate HS	Grey
27		
28		
29		
30		
31	Fan1 Pressure	Tan
32	12v Electronic	Red/White
33	0v Electronic	Black/White
34	Meter 1 Encoder	Tan
35	Meter 2 Encoder	Tan
36	Machine Speed	Tan
37	Fan 1 Encoder	Tan
38		
39		
40	Slide Gate 1	Tan
41	Slide Gate 2	Tan
42	0v High Current	Black

16

ECU 1 - X1		
Cavity	Description	Wire Color
1	Termination Sense	Tan
2	CAN-L	Green
3	CAN-GND	Black/White
4	0v Electronic	Black/White
5	0v High Current	Black
6	0v High Current	Black
7	0v High Current	Black
8	0v High Current	Black
9	Plug	
10	CAN-H	Yellow
11	CAN-EN	Pink
12	12v Electronic	Red/White
13	12v High Current	Red
14	12v High Current	Red
15	12v High Current	Red
16	12v High Current	Red

17

ISO Out - X3		
Cavity	Description	Wire Color
1	0v High Current	Black
2	0v Electronic	Black/White
3	12v High Current	Red
4	12v Electronic	Red/White
5	Termination Control	Tan
6	CAN-EN	Pink
7	CAN-GND	Black/White
8	CAN-H	Yellow
9	CAN-L	Green

18

Scale/CAN - X2		
Cavity	Description	Wire Color
1	12v Electronic	Red/White
2	CAN-H	Yellow
3	0v Electronic	Black/White
4	CAN-L	Green
5	Plug	
6	Plug	

19

ISO Input - X4		
Cavity	Description	Wire Color
1	Plug	
2	CAN-L	Green
3	CAN-GND	Black/White
4	0v Electronic	Black/White
5	0v High Current	Black
6	0v High Current	Black
7	0v High Current	Black
8	0v High Current	Black
9	Plug	
10	CAN-H	Yellow
11	CAN-EN	Pink
12	12v Electronic	Red/White
13	12v High Current	Red
14	12v High Current	Red
15	12v High Current	Red
16	12v High Current	Red

23

ECU Connection - X2		
Cavity	Description	Wire Color
1	Plug	
2	CAN-L	Green
3	CAN-GND	Black/White
4	0v Electronic	Black/White
5	0v High Current	Black
6	0v High Current	Black
7	0v High Current	Black
8	0v High Current	Black
9	Plug	
10	CAN-H	Yellow
11	CAN-EN	Pink
12	12v Electronic	Red/White
13	12v High Current	Red
14	12v High Current	Red
15	12v High Current	Red
16	12v High Current	Red

20

ISO Tractor - X1		
Cavity	Description	Wire Color
1	0v High Current	Black
2	0v Electronic	Black/White
3	12v High Current	Red
4	12v Electronic	Red/White
5	Termination Control	Tan
6	CAN-EN	Pink
7	CAN-GND	Black/White
8	CAN-H	Yellow
9	CAN-L	Green

21

Remote Master - X3		
Cavity	Description	Wire Color
1	Master Switch	Tan
2	0v Electronic	Black/White

22

Remote Master - X4		
Cavity	Description	Wire Color
1	Master Switch	Tan
2	0v Electronic	Black/White

# Gen 1 Harness Diagram

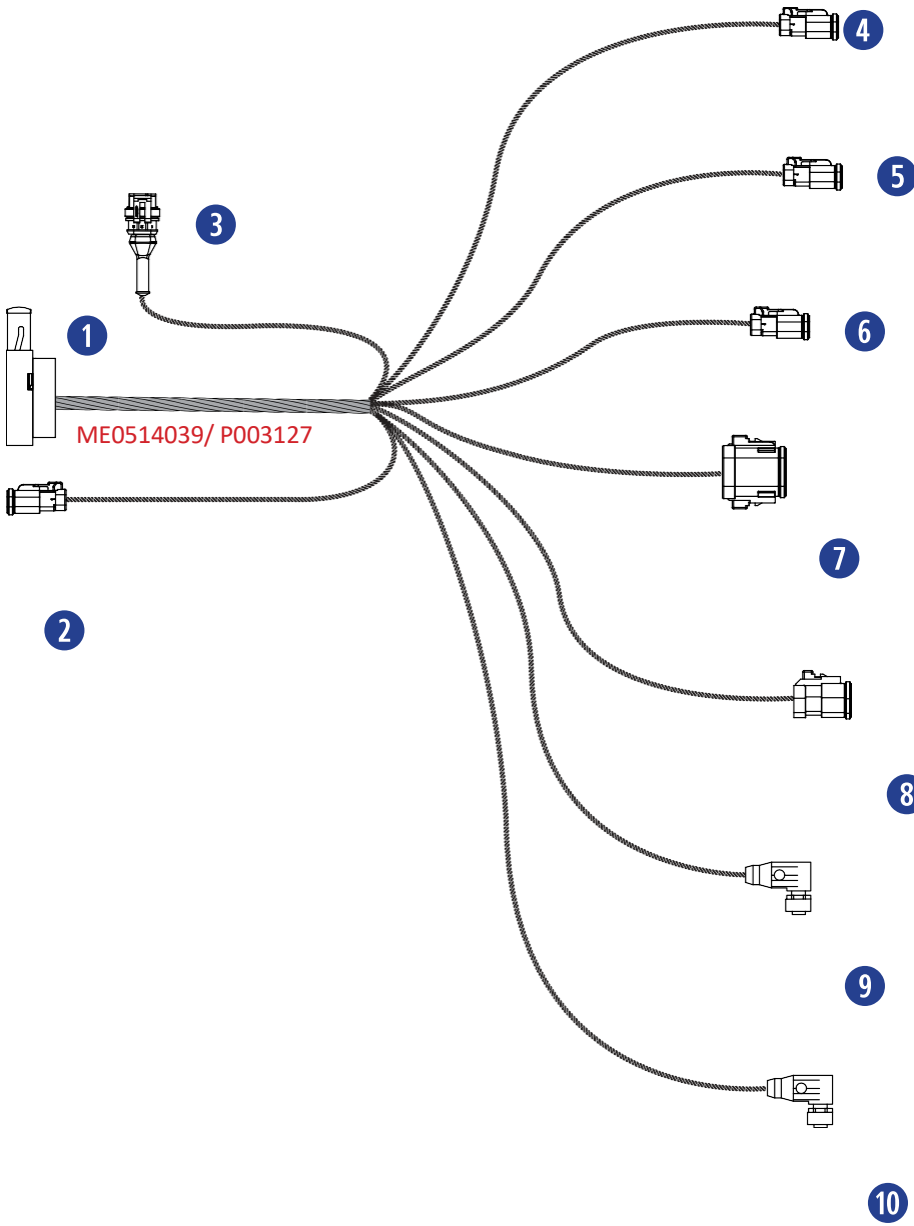

# Gen 1 Cable Pin Diagrams

**1**

Main - X1		
Cavity	Description	Wire Color
1	12v High Current	Red
2	Bin 1 Pressure	Tan
3	Bin 2 Pressure	Tan
4	5v Electronic	Red/White
5		
6		
7		
8		
9		
10		
11		
12		
13		
14		
15	Aux Output 1	Grey
16	Work Position	Tan
17	Case Drain Sensor	Tan
18	Fan 2 Pressure	Grey
19	Fan 1 PWM HS	Grey
20		
21	PWM Meter 1	Grey
22	PWM Meter 2	Grey
23	Fan 2 PWM	Grey
24		
25		
26		
27		
28		
29		
30	Fan 2 Encoder	Grey
31	Fan 1 Pressure	Tan
32	12v Electronic	Red/White
33	0v Electronic	Black/White
34	Meter 1 Encoder	Tan
35	Meter 2 Encoder	Tan
36	Machine Speed	Tan
37	Fan 1 Encoder	Tan
38		
39		
40		
41		
42	0v High Current	Black

**2**

Imp Switch - X10		
Cavity	Description	Wire Color
1	Imp Switch	Tan
2	0v Electronic	Black

**3**

Ground Speed - X11		
Cavity	Description	Wire Color
1	0v Electronic	Black/White
2	12v Electronic	Red/White
3	Machine Speed Signal	Tan

**4**

Hydraulic Alarm - X8		
Cavity	Description	Wire Color
1	Case Drain	Tan
2	0v Electronic	Black

**5**

PWM Meter 1 - X2		
Cavity	Description	Wire Color
1	PWM Meter 1	Grey
2	0v High Current	Black

**6**

PWM Meter 2 - X3		
Cavity	Description	Wire Color
1	PWM Meter 2	Grey
2	0v High Current	Black

**7**

Aux - 18		
Cavity	Description	Wire Color
1	12v High Current	Red
2	Bin 1 Pressure	Tan
3	Bin 2 Pressure	Tan
4	12v Electronic	Red/White
5	0v Electronic	Black/White
6	Fan 1 Encoder	Tan
7	Fan 2 Pressure	Tan
8	Fan 2 Encoder	Tan
9	Fan 1 PWM	Grey
10	Aux Output 1	Grey
11	Fan 2 PWM	Grey
12	0v High Current	Black

**8**

Fan Pressure Sensor - X17		
Cavity	Description	Wire Color
A	12v Electronic	Red/White
B	Fan Pressure Sensor	Tan
C	0v Electronic	Black/White

**9**

Encoder Hopper 1 - X6		
Cavity	Description	Wire Color
1	12v Electronic	Red/White
2		
3	0v Electronic	Black/White
4	Meter 1 Encoder	Tan
5	5v Electronic	Red/White

**10**

Encoder Hopper 2 - X7		
Cavity	Description	Wire Color
1	12v Electronic	Red/White
2		
3	0v Electronic	Black/White
4	Meter 2 Encoder	Tan
5	5v Electronic	Red/White

# Fortifier Harness Diagram

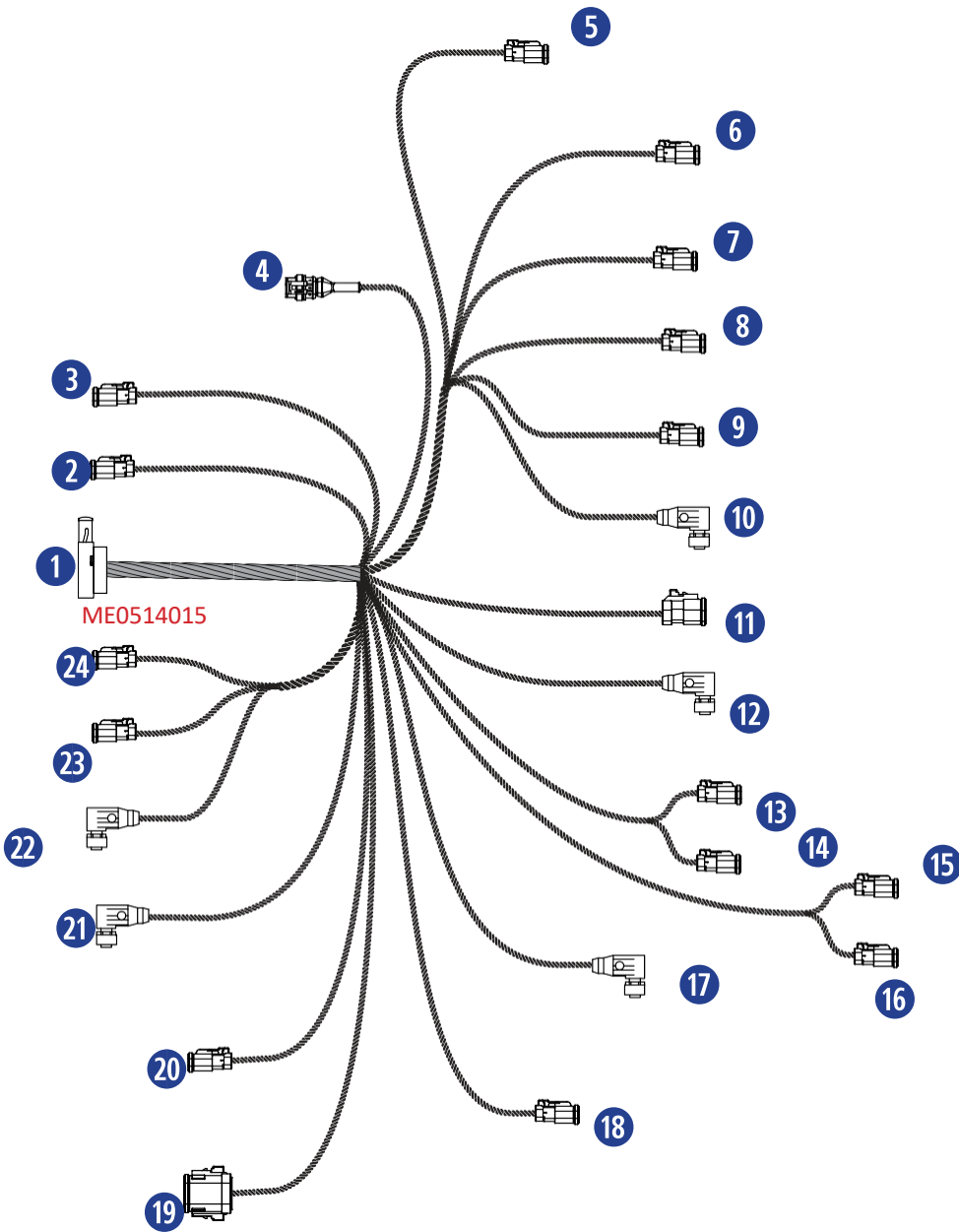

# Fortifier Cable Pin Diagrams

1

Main - X1		ME0514015
Cavity	Description	Wire Color
1	12v High Current	Red
2	Fan 2 Pressure Sensor	Tan
3	Fan 3 Encoder	Tan
4		
5	Aux Output 1	Grey
6		
7	Section W	Grey
8	Section X	Grey
9	Section Y	Grey
10	Section Z	Grey
11		
12		
13		
14	Aux Input	Tan
15	Fan 3 PWM	Grey
16	Work Position	Tan
17	Case Drain	Tan
18	Fan 2 Pressure	Grey
19	Fan 1 PWM	Grey
20		
21	PWM Meter 1	Grey
22	PWM Meter 2	Grey
23	Fan 2 PWM	Grey
24		
25	Open Gate HS	Grey
26	Close Gate HS	Grey
27		
28		
29		
30	Fan 2 Encoder	Grey
31	Fan1 Pressure	Tan
32	12v Electronic	Red/White
33	0v Electronic	Black/White
34	Meter 1 Encoder	Tan
35	Meter 2 Encoder	Tan
36	Machine Speed	Tan
37	Fan 1 Encoder	Tan
38	Gate Sensor 1	Tan
39	Gate Sensor 2	Tan
40		
41		
42	0v High Current	Black

2

Section Z - X21		ME0514015
Cavity	Description	Wire Color
1	Section Z	Grey
2	0v High Current	Black

3

Section Y - X20		ME0514015
Cavity	Description	Wire Color
1	Section Y	Grey
2	0v High Current	Black

4

Ground Speed - X11		ME0514015
Cavity	Description	Wire Color
1	0v Electronic	Black/White
2	12v Electronic	Red/White
3	Machine Speed Signal	Tan

5

Hydraulic Alarm - X8		ME0514015
Cavity	Description	Wire Color
1	Case Drain	Tan
2	0v Electronic	Black

6

PWM Meter 1 - X2		ME0514015
Cavity	Description	Wire Color
1	PWM Meter 1	Grey
2	0v High Current	Black

7

PWM Meter 2 - X3		ME0514015
Cavity	Description	Wire Color
1	PWM Meter 2	Grey
2	0v High Current	Black

8

Open Gate - X16		ME0514015
Cavity	Description	Wire Color
1	Open Gate HS	Grey
2	0v High Current	Black

9

Close Gate - X15		ME0514015
Cavity	Description	Wire Color
1	Close Gate HS	Grey
2	0v High Current	Black

10

Encoder Hopper 2 - X7		ME0514015
Cavity	Description	Wire Color
1	12v Electronic	Red/White
2		
3	0v Electronic	Black/White
4	Meter 2 Encoder	Tan

**11** **Fan Pressure Sensor - X17** ME0514015

Cavity	Description	Wire Color
A	12v Electronic	Red/White
B	Fan Pressure Sensor	Tan
C	0v Electronic	Black/White

**12** **Encoder Hopper 1 - X6** ME0514015

Cavity	Description	Wire Color
1	12v Electronic	Red/White
2		
3	0v Electronic	Black/White
4	Meter 2 Encoder	Tan

**13** **Section W - X25** ME0514015

Cavity	Description	Wire Color
1	Section W	Grey
2	0v High Current	Black

**14** **Section X - X26** ME0514015

Cavity	Description	Wire Color
1	Section X	Grey
2	0v High Current	Black

**15** **Section W - X27** ME0514015

Cavity	Description	Wire Color
1	Section W	Grey
2	0v High Current	Black

**16** **Section X - X28** ME0514015

Cavity	Description	Wire Color
1	Section X	Grey
2	0v High Current	Black

**17** **Bin 1 Gate - X12** ME0514015

Cavity	Description	Wire Color
1	12v Electronic	Red/White
2	Gate Sensor 2	Tan
3	0v Electronic	Black/White

**18** **PWM Fan 1 - X29** ME0514015

Cavity	Description	Wire Color
1	PWM Fan 1	Grey
2	0v High Current	Black

**19** **Aux - 18** ME0514015

Cavity	Description	Wire Color
1	12v High Current	Red
2	Fan 1 Pressure	Tan
3	Fan 2 Pressure	Tan
4	12v Electronic	Red/White
5	0v Electronic	Black/White
6	Aux Input	Tan
7	Fan 2 Pressure	Tan
8	Fan 2 Encoder	Tan
9	Aux Output 1	Grey
10	Fan 3 PWM	Grey
11	Fan 2 PWM	Grey
12	0v High Current	Black

**20** **Imp Switch - X10** ME0514015

Cavity	Description	Wire Color
1	Imp Switch	Tan
2	0v Electronic	Black

**21** **Encoder Fan 1 - X19** ME0514015

Cavity	Description	Wire Color
1	12v Electronic	Red/White
2		
3	0v Electronic	Black/White
4	Fan1 Encoder	Tan

**22** **Bin 2 Gate - X13** ME0514015

Cavity	Description	Wire Color
1	12v Electronic	Red/White
2	Gate Sensor 2	Tan
3	0v Electronic	Black/White

**23** **Section Z - X23** ME0514015

Cavity	Description	Wire Color
1	Section Z	Grey
2	0v High Current	Black

**24** **Section Y - X22** ME0514015

Cavity	Description	Wire Color
1	Section Y	Grey
2	0v High Current	Black

# Montag Page Reference Guide

(Reference list originates from the Run Screen)



Settings screen

Page 11

**Select these options under Settings:**



Hopper Settings

Page 17-18



Set virtual weight equal to scale weight

Page 11, 18, 49



Toggle between scale and virtual weight

Page 18



Hopper 1 ON/OFF

Page 17-18



Hopper 2 ON/OFF

Page 17-18



Hopper 3 ON/OFF

Page 17-18



Metering Drive Settings

Page 19-25



Catch Test Calibrations

Page 23-25



No Catch Test Calibration

Page 21-22



Weigh System Settings

Page 26



Fan Settings

Page 27



Speed Signal Settings

Page 27-29, 48



Implement Speed Calibration

Page 28-29



Configuration Settings

Page 30



Diagnostics Settings

Page 57-60

From the Configuration Settings, navigate to the following screens:

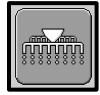

Implement Configuration Page 31-34, 46



Implement Geometry Page 33-34



Hopper Configuration Page 35

*(Set up an Associated Product)*



Product Configuration Page 43-44, 46



Product Database Page 44



Add a new Product Page 44



Meter Calibration Page 20, 44  
*(Toggle between meter calibration factor for 2 and additional Hoppers)*

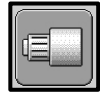

Metering Drive Configuration Page 41-42  
*(Choose a calibration method and set the Target Rate)*



Slide Gate Calibration Page 42, 47



Shoot Configuration Page 36, 47  
*(Set up the Sections, Rows, and Working Width)*



Section Configuration Page 36



Fan Configuration Page 37-38

*(Assign and calibrate an Associated Pressure Sensor)*



Fan Calibration Set-up Page 37-38, 47



Run Screen Configuration Page 39-40  
*(Customize Run Screen Feedback)*



Hopper Information Configuration Page 39



Status Line Configuration Page 40



Bottom Area Configuration Page 40



Center Area Configuration Page 40



Profile Database Configuration Page 45  
*(Select and save new profiles)*



Locked Area Page 45  
*(Unlocks additional features for Dealer and OEM only)*

From the Diagnostics Settings, navigate to the following screens:

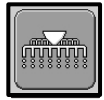

Implement Diagnostics Page 57



Hopper Diagnostics Page 57



Metering Drive Diagnostics Page 58



Gate Open Page 15, 49, 58



Gate Close Page 15, 49, 58



Fan Diagnostics Page 57



Sections Diagnostics Page 58



Alarms Page 59



ECU Diagnostics Page 59



Hydraulics Page 9, 15



Road Mode Page 9, 11, 49 11, 12, 17, 50



Gate Open Page 15, 58



Gate Close Page 15, 58



Results Page 15, 53-55



Season Clear Page 54



Trip Clear Page 54



Total Results Page 55



Set virtual weight equal to scale weight Page 11, 18, 49

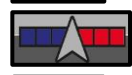

Auto/Manual Section Control Page 53



Master Control Page 9, 11, 15



# Calibration Chart for Machine Types

MACHINE TYPE	CAL/ROW	NUMBER OF ROW MACHINE					
		8	9	12	16	18	24
	FT <sup>2</sup> /ROW						
GEN 1 STANDARD OUTPUT (2" HOSES)	0.0016	0.0128	X	0.0192	0.0256	0.0288	X
GEN 1 HIGH OUTPUT (2.5" HOSES)	0.0032	0.0256	X	0.0384	0.0512	0.0576	0.0768
GEN 2	0.0026	0.0208	X	0.0312	0.0416	0.0468	X
FORTIFIER	0.0026	X	0.0234	0.0312	X	X	X
2108	0.0026	0.0208	X	X	X	X	X
2208	0.0026	0.0208	X	X	X	X	X







**Montag Manufacturing, Inc.**  
**3816 461st Avenue**  
**Emmetsburg, IA 50536**  
**Phone: (712) 852-4572**  
**FAX: (712) 852-4574**  
**Tech Support: (712) 852-4572**

or

[support@montagmfg.com](mailto:support@montagmfg.com)

Visit us at:

[www.montagmfg.com](http://www.montagmfg.com)



(WARRANTY REGISTRATION)